

INSTALLER: LEAVE THIS MANUAL WITH THE APPLIANCE.
CONSUMER: RETAIN THIS MANUAL FOR FUTURE REFERENCE.



INSTALLATION AND OPERATING INSTRUCTIONS

CERTIFIED UNDER CANADIAN AND AMERICAN NATIONAL STANDARDS: CSA 2.22, ANSI Z21.50 FOR VENTED GAS FIREPLACE.

TORCH™

GT8N NATURAL GAS

GT8P PROPANE

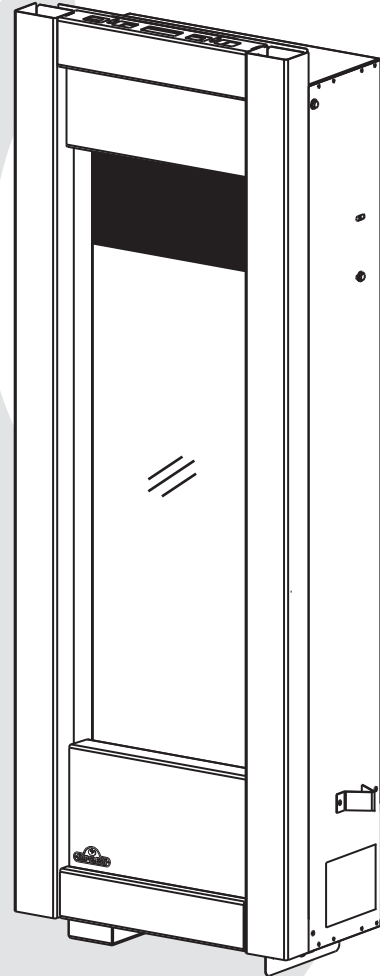

CERTIFIED FOR CANADA AND UNITED STATES USING ANSI/CSA METHODS.

SAFETY INFORMATION

WARNING

If the information in these instructions are not followed exactly, a fire or explosion may result causing property damage, personal injury or loss of life.

- Do not store or use gasoline or other flammable vapors and liquids in the vicinity of this or any other appliance.
- WHAT TO DO IF YOU SMELL GAS:
 - Do not try to light any appliance.
 - Do not touch any electrical switch; do not use any phone in your building.
 - Immediately call your gas supplier from a neighbour's phone. Follow the gas supplier's instructions.
 - If you cannot reach your gas supplier, call the fire department.
- Installation and service must be performed by a qualified installer, service agency or the supplier.



Wolf Steel Ltd., 24 Napoleon Rd., Barrie, ON, L4M 4Y8 Canada /
103 Miller Drive, Crittenden, Kentucky, USA, 41030
Phone (705)721-1212 • Fax (705)722-6031 • www.napoleonfireplaces.com • ask@napoleon.on.ca

TABLE OF CONTENTS

1.0	INTRODUCTION	3
1.1	WARRANTY	4
1.2	DIMENSIONS	5
1.3	GENERAL INSTRUCTIONS	5
1.4	GENERAL INFORMATION	6
1.5	CARE OF GLASS	7
2.0	VENTING	7
2.1	VENTING LENGTHS AND COMPONENTS	8
2.2	VENT TERMINAL CLEARANCES	9
2.3	HORIZONTAL TERMINATION	10
2.4	VERTICAL TERMINATION	11
3.0	INSTALLATION	12
3.1	WALL AND CEILING PROTECTION	12
3.2	HORIZONTAL INSTALLATION	12
3.3	VERTICAL INSTALLATION	13
3.4	USING FLEXIBLE VENT COMPONENTS	14
3.4.1	HORIZONTAL AIR TERMINAL INSTALLATION	14
3.4.2	VERTICAL AIR TERMINAL INSTALLATION	15
3.4.3	APPLIANCE VENT CONNECTION	16
3.5	MOBILE HOME	16
3.6	GAS INSTALLATION	17
3.7	ELECTRICAL CONNECTION	17
3.8	HARD WIRING CONNECTION	18
3.9	STAND-OFF ASSEMBLY	18
3.10	NAILING TAB INSTALLATION	19
3.11	FRAMING	19
3.12	MINIMUM CLEARANCE TO COMBUSTIBLES	21
4.0	FINISHING	22
4.1	MOUNTING CABINET INSTALLATION	22
4.2	DOOR REMOVAL	23
4.3	GLASS REMOVAL	23
4.4	FRAME/FRONT INSTALLATION	23
4.5	ACCENT GLASS INSTALLATION	24
4.6	LK8 LIGHT INSTALLATION (OPTIONAL)	25
5.0	OPERATION	26
6.0	RATING PLATE	27
7.0	ADJUSTMENTS	27
7.1	GAS PRESSURE ADJUSTMENT	27
7.2	VENTURI ADJUSTMENT	28
7.3	FLAME CHARACTERISTICS	28
8.0	MAINTENANCE	28
9.0	REPLACEMENTS	29
10.0	TROUBLE SHOOTING	32
11.0	SERVICE HISTORY	34
12.0	NOTES	35

NOTE: Changes, other than editorial, are denoted by a line in the margin.

1.0 INTRODUCTION

WARNING

- Do not operate appliance before reading and understanding operating instructions. Failure to operate appliance according to operating instructions could cause fire or injury.
- Risk of fire or asphyxiation do not operate appliance with fixed glass removed.
- Do not connect 110 volts to the control valve.
- Risk of burns. The appliance should be turned off and cooled before servicing.
- Do not install damaged, incomplete or substitute components.
- Risk of cuts and abrasions. Wear protective gloves and safety glasses during installation. Sheet metal edges may be sharp.
- Do not burn wood or other materials in this appliance.
- Young children should be carefully supervised when they are in the same room as the appliance. Toddlers, young children and others may be susceptible to accidental contact burns. A physical barrier is recommended if there are at risk individuals in the house. To restrict access to an appliance or stove, install an adjustable safety gate to keep toddlers, young children and other at risk individuals out of the room and away from hot surfaces.
- Clothing or other flammable material should not be placed on or near the appliance.
- Due to high temperatures, the appliance should be located out of traffic and away from furniture and draperies.
- Ensure you have incorporated adequate safety measure to protect infants/toddlers from touching hot surfaces.
- Even after the appliance is out, the glass and/or screen will remain hot for an extended period of time.
- Check with your local hearth specialty dealer for safety screens and hearth guards to protect children from hot surfaces. These screens and guards must be fastened to the floor.
- Any safety screen or guard removed for servicing must be replaced prior to operating the appliance.
- It is imperative that the control compartments, burners and circulating blower and its passageway in the appliance and venting system are kept clean. The appliance and its venting system should be inspected before use and at least annually by a qualified service person. More frequent cleaning may be required due to excessive lint from carpeting, bedding material, etc. The appliance area must be kept clear and free from combustible materials, gasoline and other flammable vapors and liquids.
- Under no circumstances should this appliance be modified.
- This appliance must not be connected to a chimney flue pipe serving a separate solid fuel burning appliance.
- Do not use this appliance if any part has been under water. Immediately call a qualified service technician to inspect the appliance and to replace any part of the control system and any gas control which has been under water.
- Do not operate the appliance with the glass door removed, cracked or broken. Replacement of the glass should be done by a licensed or qualified service person.
- Do not strike or slam shut the appliance glass door.
- This appliance uses and requires a fast acting thermocouple. Replace only with a fast acting thermocouple supplied by Wolf Steel Ltd.
- Pressure relief doors must be kept closed while the appliance is operating to prevent exhaust fumes containing carbon monoxide, from entering into the home. Temperatures of the exhaust escaping through these openings can also cause the surrounding combustible materials to overheat and catch fire.
- Only doors / optional fronts certified with the unit are to be installed on the appliance.
- Keep the packaging material out of reach of children and dispose of the material in a safe manner. As with all plastic bags, these are not toys and should be kept away from children and infants.
- As with any combustion appliance, we recommend having your appliance regularly inspected and serviced as well as having a Carbon Monoxide Detector installed in the same area to defend you and your family against Carbon Monoxide.

1.1 WARRANTY

NAPOLEON® products are manufactured under the strict Standard of the world recognized ISO 9001 : 2000 Quality Assurance Certificate.

NAPOLEON® products are designed with superior components and materials assembled by trained craftsmen who take great pride in their work. The burner and valve assembly are leak and test-fired at a quality test station. The complete heater is again thoroughly inspected by a qualified technician before packaging to ensure that you, the customer, receives the quality product that you expect from NAPOLEON®.

NAPOLEON® GAS FIREPLACE PRESIDENT'S LIFETIME LIMITED WARRANTY

The following materials and workmanship in your new NAPOLEON® gas heater are warranted against defects for as long as you own the heater. This covers: combustion chamber, heat exchanger, stainless steel burner, phazer™ logs and embers, rocks, ceramic glass (thermal breakage only), gold plated parts against tarnishing, porcelainized enameled components and aluminum extrusion trims.*
Electrical (110V and millivolt) components and wearable parts such as blowers, gas valves, thermal switch, switches, wiring, remote controls, ignitor, gasketing, and pilot assembly are covered and NAPOLEON® will provide replacement parts free of charge during the first year of the limited warranty.*
Labour related to warranty repair is covered free of charge during the first year. Repair work, however, requires the prior approval of an authorized company official. Labour costs to the account of NAPOLEON® are based on a predetermined rate schedule and any repair work must be done through an authorized NAPOLEON® dealer.

* Construction of models vary. Warranty applies only to components included with your specific heater.

CONDITIONS AND LIMITATIONS

NAPOLEON® warrants its products against manufacturing defects to the original purchaser only. Registering your warranty is not necessary. Simply provide your proof of purchase along with the model and serial number to make a warranty claim. NAPOLEON® reserves the right to have its representative inspect any product or part thereof prior to honouring any warranty claim. Provided that the purchase was made through an authorized NAPOLEON® dealer your heater is subject to the following conditions and limitations:

This factory warranty is non-transferable and may not be extended whatsoever by any of our representatives.

The gas heater must be installed by a licensed, authorized service technician or contractor. Installation must be done in accordance with the installation instructions included with the product and all local and national building and fire codes. This limited warranty does not cover damages caused by misuse, lack of maintenance, accident, alterations, abuse or neglect and parts installed from other manufacturers will nullify this warranty.

This limited warranty further does not cover any scratches, dents, corrosion or discoloring caused by excessive heat, abrasive and chemical cleaners nor chipping on porcelain enamel parts, mechanical breakage of PHAZER™ logs and embers.

NAPOLEON® warrants its stainless steel burners against defects in workmanship and material for life, subject to the following conditions: During the first 10 years NAPOLEON® will replace or repair the defective parts at our option free of charge. From 10 years to life, NAPOLEON® will provide replacement burners at 50% of the current retail price.

In the first year only, this warranty extends to the repair or replacement of warranted parts which are defective in material or workmanship provided that the product has been operated in accordance with the operation instructions and under normal conditions.

After the first year, with respect to this President's Lifetime Limited Warranty, NAPOLEON® may, at its discretion, fully discharge all obligations with respect to this warranty by refunding to the original warranted purchaser the wholesale price of any warranted but defective part(s).

NAPOLEON® will not be responsible for installation, labour or any other expenses related to the reinstallation of a warranted part and such expenses are not covered by this warranty.

Notwithstanding any provisions contained in the President's Lifetime Limited Warranty, NAPOLEON'S responsibility under this warranty is defined as above and it shall not in any event extend to any incidental, consequential or indirect damages.

This warranty defines the obligations and liability of NAPOLEON® with respect to the NAPOLEON® gas heater and any other warranties expressed or implied with respect to this product, its components or accessories are excluded.

NAPOLEON® neither assumes, nor authorizes any third party to assume, on its behalf, any other liabilities with respect to the sale of this product.

NAPOLEON® will not be responsible for: over-firing, downdrafts, spillage caused by environmental conditions such as rooftops, buildings, nearby trees, hills, mountains, inadequate vents or ventilation, excessive venting configurations, insufficient makeup air, or negative air pressures which may or may not be caused by mechanical systems such as exhaust fans, furnaces, clothes dryers, etc.

Any damages to heater, combustion chamber, heat exchanger, brass trim or other components due to water, weather damage, long periods of dampness, condensation, damaging chemicals or cleaners will not be the responsibility of NAPOLEON®.

ALL SPECIFICATIONS AND DESIGNS ARE SUBJECT TO CHANGE WITHOUT PRIOR NOTICE DUE TO ON-GOING PRODUCT IMPROVEMENTS. NAPOLEON® IS A REGISTERED TRADEMARK OF WOLF STEEL LTD. PATENTS U.S. 5.303.693.801 - CAN. 2.073.411, 2.082.915. © WOLF STEEL LTD.

1.2 DIMENSIONS

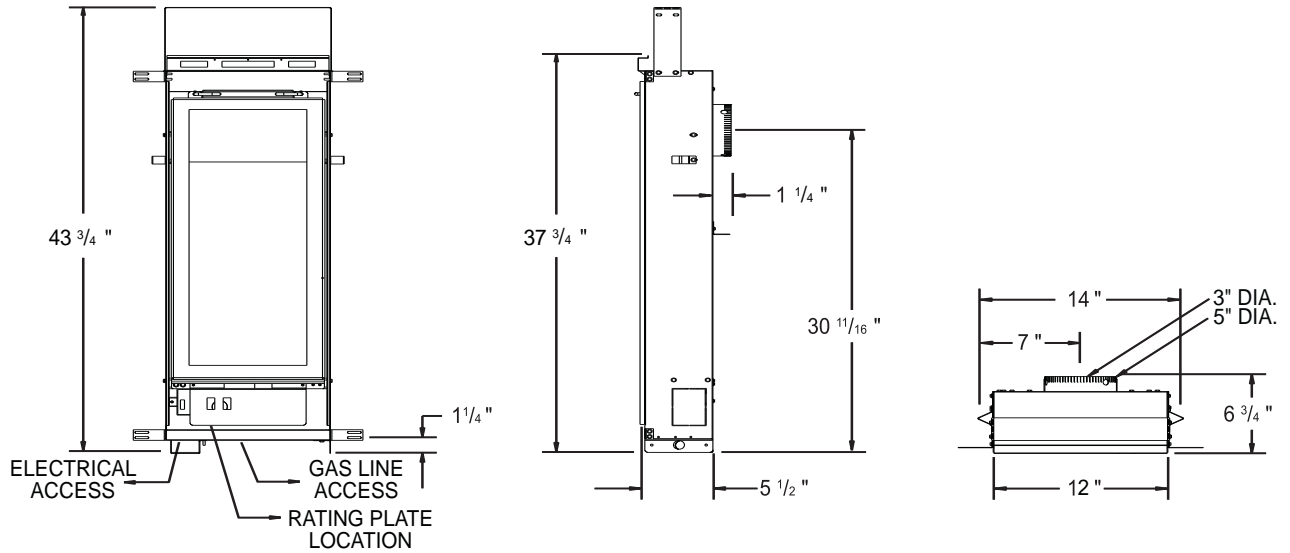

1.3 GENERAL INSTRUCTIONS

! WARNING
ALWAYS LIGHT THE PILOT WHETHER FOR THE FIRST TIME OR IF THE GAS SUPPLY HAS RAN OUT, WITH THE GLASS DOOR OPENED OR REMOVED.
PROVIDE ADEQUATE ACCESSIBILITY CLEARANCE FOR SERVICING AND OPERATING THE APPLIANCE.
PROVIDE ADEQUATE VENTILATION.
NEVER OBSTRUCT THE FRONT OPENING OF THE APPLIANCE.
OBJECTS PLACED IN FRONT OF THE APPLIANCE MUST BE KEPT A MINIMUM OF 48" FROM THE FRONT FACE OF THE UNIT.
THIS PRODUCT MUST BE INSTALLED BY A LICENSED PLUMBER OR GAS FITTER WHEN INSTALLED WITHIN THE COMMONWEALTH OF MASSACHUSETTS.
FIRE RISK. EXPLOSION HAZARD.
HIGH PRESSURE WILL DAMAGE VALVE. DISCONNECT GAS SUPPLY PIPING BEFORE PRESSURE TESTING GAS LINE AT TEST PRESSURES ABOVE 1/2 PSIG. CLOSE THE MANUAL SHUT-OFF VALVE BEFORE PRESSURE TESTING GAS LINE AT TEST PRESSURES EQUAL TO OR LESS THAN 1/2 PSIG.
USE ONLY WOLF STEEL APPROVED OPTIONAL ACCESSORIES AND REPLACEMENT PARTS WITH THIS APPLIANCE. USING NON-LISTED ACCESSORIES (BLOWERS, DOORS, LOUVRES, TRIMS, GAS COMPONENTS, VENTING COMPONENTS, ETC.) COULD RESULT IN A SAFETY HAZARD AND WILL VOID THE WARRANTY AND CERTIFICATION.

THIS GAS APPLIANCE SHOULD BE INSTALLED AND SERVICED BY A QUALIFIED INSTALLER to conform with local codes. Installation practices vary from region to region and it is important to know the specifics that apply to your area, for example in Massachusetts State:

- The appliance damper must be removed or welded in the open position prior to installation of a appliance insert or gas log.
- The appliance off valve must be a “T” handle gas cock.
- The flexible connector must not be longer than 36 inches.
- A Carbon Monoxide detector is required in all rooms containing gas fired appliances.
- The appliance is not approved for installation in a bedroom or bathroom unless the unit is a direct vent sealed combustion product.

The installation must conform with local codes or, in absence of local codes, the National Gas and Propane Installation Code CSA B149.1 in Canada, or the National Fuel Gas Code, ANSI Z223.1 / NFPA 54 in the United States. Suitable for mobile home installation if installed in accordance with the current standard CAN/CSA Z240MH Series, for gas equipped mobile homes, in Canada or ANSI Z223.1 and NFPA 54 in the United States.

**NATIONAL
FIREPLACE
INSTITUTE**



CERTIFIED

www.nficertified.org

We suggest that our gas hearth products be installed and serviced by professionals who are certified in the U.S. by the National Appliance Institute® (NFI) as NFI Gas Specialists

As long as the required clearance to combustibles is maintained, the most desirable and beneficial location for an appliance is in the center of a building, thereby allowing the most efficient use of the heat created. The location of windows, doors and the traffic flow in the room where the appliance is to be located should be considered. If possible, you should choose a location where the vent will pass through the house without cutting a floor or roof joist.

When the appliance is installed directly on carpeting, vinyl tile or other combustible material other than wood flooring, the appliance shall be installed on a metal or wood panel extending the full width and depth.

4.1

1.4 GENERAL INFORMATION

FOR YOUR SATISFACTION, THIS APPLIANCE HAS BEEN TEST-FIRED TO ASSURE ITS OPERATION AND QUALITY!

This appliance is approved for bathroom, bedroom and bed-sitting room installations and is suitable for mobile home installation. The natural gas model can only be installed in a mobile home that is permanently positioned on its site and fueled with natural gas. This appliance may be installed in an aftermarket permanently located, manufactured (mobile) home, where not prohibited by local codes.

This appliance is only for use with the type of gas indicated on the rating plate. This appliance is not convertible for use with other gases, unless a certified kit is used.

Expansion / contraction noises during heating up and cooling down cycles are normal and are to be expected.

RATES AND EFFICIENCIES

	NATURAL GAS	PROPANE GAS
Altitude	0 - 4,500*	0 - 4,500*
Maximum Input	6,000	6,000
Maximum Output	4,680	4,680
Efficiency	78%	78%
Minimum Inlet Gas Supply Pressure	4.5" Water Column	11" Water Column
Maximum Inlet Gas Supply Pressure	7" Water Column	13" Water Column
Manifold Pressure Under Flow Conditions	3.5" Water Column	10" Water Column

* When the appliance is installed at elevations above 4,500ft, and in the absence of specific recommendations from the local authority having jurisdiction, the certified high altitude input rating shall be reduced at the rate of 4% for each additional 1,000ft.

1.5 CARE OF GLASS

DO NOT CLEAN GLASS WHEN HOT! DO NOT USE ABRASIVE CLEANERS TO CLEAN GLASS.

Buff lightly with a clean dry soft cloth. Clean the glass after the first 10 hours of operation with a recommended fireplace glass cleaner. Thereafter clean as required. If the glass is not kept clean permanent discoloration and / or blemishes may result.



5.1

2.0 VENTING

! WARNING
RISK OF FIRE, MAINTAIN SPECIFIED AIR SPACE CLEARANCES TO VENT PIPE AND APPLIANCE.
<p>THE VENT SYSTEM MUST BE SUPPORTED EVERY 3 FEET FOR BOTH VERTICAL AND HORIZONTAL RUNS. USE SUPPORTS OR EQUIVALENT NON-COMBUSTIBLE STRAPPING TO MAINTAIN THE REQUIRED CLEARANCE FROM COMBUSTIBLES. SPACERS ARE ATTACHED TO THE INNER FLEX PIPE AT PREDETERMINED INTERVALS TO MAINTAIN AN EVEN AIR GAP TO THE OUTER FLEX PIPE. THIS GAP IS REQUIRED FOR SAFE OPERATION. A SPACER IS REQUIRED AT THE START, MIDDLE AND END OF EACH ELBOW TO ENSURE THIS GAP IS MAINTAINED. THESE SPACERS MUST NOT BE REMOVED. USE WOLF STEEL LTD. SUPPORT RING ASSEMBLY W010-0370 OR EQUIVALENT NON-COMBUSTIBLE STRAPPING TO MAINTAIN THE MINIMUM CLEARANCE TO COMBUSTIBLES FOR BOTH VERTICAL AND HORIZONTAL RUNS.</p>

THIS APPLIANCE USES A 3" EXHAUST / 5" AIR INTAKE VENT PIPE SYSTEM.

Refer to the section applicable to your installation.

For safe and proper operation of the appliance follow the venting instruction exactly. Deviation from the minimum vertical vent length can create difficulty in burner start-up and/or carboning. Under extreme vent configurations, allow several minutes (5-15) for the flame to stabilize after ignition. Vent lengths that pass through unheated spaces (attics, garages, crawl spaces) should be insulated with the insulation wrapped in a protective sleeve to minimize condensation. Provide a means for visually checking the vent connection to the appliance after the appliance is installed. Use a firestop, vent pipe shield or attic insulation shield when penetrating interior walls, floor or ceiling.

NOTE: If for any reason the vent air intake system is disassembled; reinstall per the instructions provided for the initial installation.

7.4

2.1 VENTING LENGTHS AND COMPONENTS

The vent connection to the appliance can be viewed by removing the baffle from the top, inside of the firebox.

Use only Wolf Steel venting components. Minimum and maximum vent lengths, for both horizontal and vertical installations, and air terminal locations for either system are set out in this manual and must be adhered to. **Use only Wolf Steel Ltd. flexible vent components with the Wolf Steel Ltd. GD179 termination kit.** This appliance uses a 3" diameter exhaust and a 5" diameter intake coaxial vent system.

All outer pipe joints of these venting systems must be sealed using Red RTV and/or Mill Pac high temperature sealant (not supplied) hereafter referred to as high temperature sealant W573-0002 (Red RTV) and the high temperature sealant W573-0007 (Mill Pac).

For vent systems that provide seals on the inner exhaust flue, only the outer air intake joints must be sealed using a red high temperature silicone (RTV). This same sealant may be used on both the inner exhaust and outer intake vent pipe joints of all other approved vent systems except for the exhaust vent pipe connection to the appliance flue collar which must be sealed using the black high temperature sealant Mill Pac.

With flexible venting, in conjunction with the **GD178 wall terminal kit**, use either the 5 foot vent kit **GDT5** or the 10 foot vent kit **GDT10**. These kits allow for extended horizontal venting of the appliance. When using approved Wolf Steel venting components, use only the following termination kits: WALL TERMINAL KIT **GD178**, or 1/12 TO 7/12 PITCH ROOF TERMINAL KIT **GDT110**, 8/12 TO 12/12 ROOF TERMINAL KIT **GDT111**, FLAT ROOF TERMINAL KIT **GDT112**.

For optimum flame appearance and appliance performance, keep the vent length and number of elbows to a minimum.

The air terminal must remain unobstructed at all times. Examine the air terminal at least once a year to verify that it is unobstructed and undamaged.

Rigid and flexible venting systems must not be combined. Different venting manufacturer components must not be combined.

Vent terminals shall not be recessed into a wall or siding.

These vent kits allow for either horizontal or vertical venting of the appliance. The maximum allowable horizontal run is 7 feet. The maximum allowable vertical vent length is 19 ½ feet. The maximum number of vent connections is two horizontally or three vertically (excluding the appliance and the air terminal connections) when using flexible venting.

2.2 VENT TERMINAL CLEARANCES

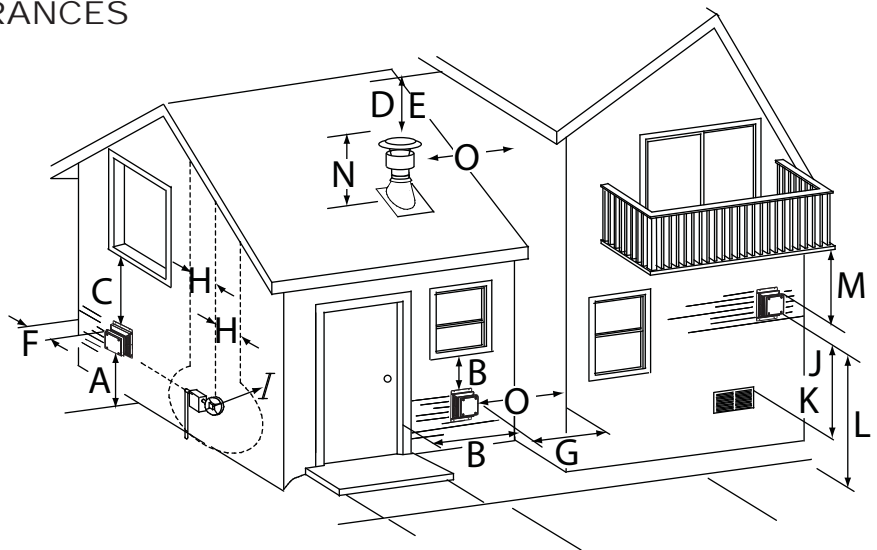

INSTALLATIONS			
	CANADA	U.S.A.	
A	12"	12"	Clearance above grade, veranda porch, deck or balcony.
B	12"	9"	Clearance to windows or doors that open.
C	12" *	12" *	Clearance to permanently closed windows.
D	18" **	18" **	Vertical clearance to ventilated soffits located above the terminal within a horizontal distance of 2' from the centerline of the terminal.
E	12" **	12" **	Clearance to unventilated soffit.
F	0"	0"	Clearance to an outside corner wall.
G	0" ***	0" ***	Clearance to an inside non -combustible corner wall or protruding non -combustible obstructions (chimney, etc.).
	2" ***	2" ***	Clearance to an inside combustible corner wall or protruding combustible obstructions (vent chase, etc.).
H	3'	3' ****	Clearance to each side of the centerline extended above the meter / regulator assembly to a maximum vertical distance of 15'.
I	3'	3' ****	Clearance to a service regulator vent outlet.
J	12"	9"	Clearance to a non-mechanical air supply inlet to the building or a combustion air inlet to any other appliance.
K	6'	3' †	Clearance to a mechanical air supply inlet.
L	7' ‡	7' ****	Clearance above a paved sidewalk or paved driveway located on public property.
M	12" ††	12" ****	Clearance under a veranda, porch, deck or balcony.
N	16"	16"	Clearance above the roof.
O	2' †*	2' †*	Clearance from an adjacent wall including neighbouring buildings.
*	Recommended to prevent condensation on windows and thermal breakage		
**	it is recommended to use a heat shield and to maximize the distance to vinyl clad soffits.		
***	The periscope requires a minimum 18 inches clearance from an inside corner.		
****	This is a recommended distance. For additional requirements check local codes.		
†	3 feet above if within 10 feet horizontally.		
‡	A vent shall not terminate directly above a sidewalk or paved driveway that is located between two single family dwellings and serves both dwellings.		
††	Permitted only if the veranda, porch, or deck is fully open on a minimum of two sides beneath the floor.		
†*	Recommended to prevent recirculation of exhaust products. For additional requirements check local codes.		

NOTE: Clearances are in accordance with local installation codes and the requirements of the gas supplier.

2.3 HORIZONTAL TERMINATION

	MIN	MAX
Allowable 3" vent connections (excluding appliance and air terminal connections)	N/A	1
Rise per foot (recommended)	1/4"	N/A
Rise per foot (allowable)	0"	N/A
Horizontal run (If vent run does not include vertical rise)	4"	24"
Horizontal run (if vent run includes vertical rise)	4"	7 FT
Vertical run (* Immediately off the appliance, if 7 FT maximum horizontal run is required)	18"*	7 FT

See graph to determine the required vertical rise V_T for the required horizontal rise H_T .

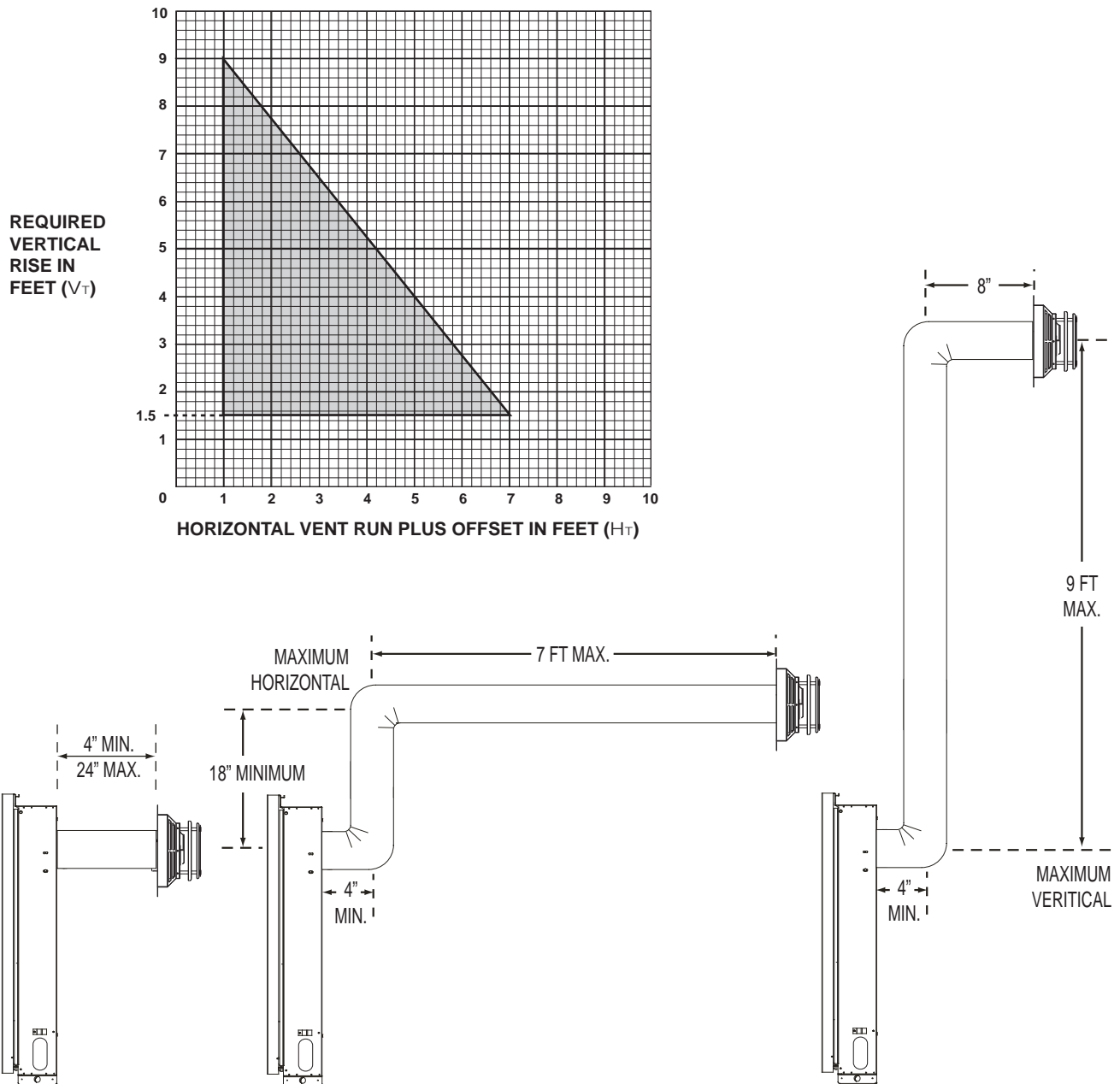

2.4 VERTICAL TERMINATION

	MIN	MAX
Allowable 3" vent connections (excluding appliance and air terminal connections)	N/A	2
Rise per foot (recommended)	1/4"	N/A
Rise per foot (allowable)	0"	N/A
Vertical run (when not venting horizontally)	24"	19 1/2 FT
Horizontal run	4"	5 FT

See graph to determine the required vertical rise V_T for the required horizontal rise H_T .

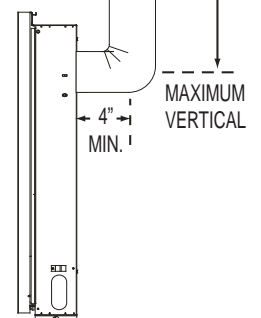
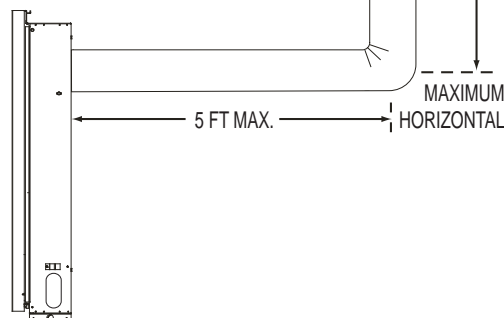
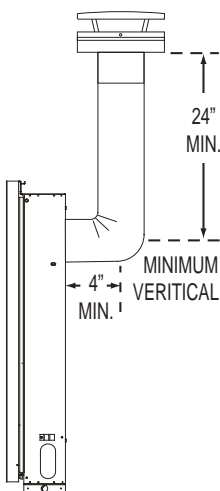
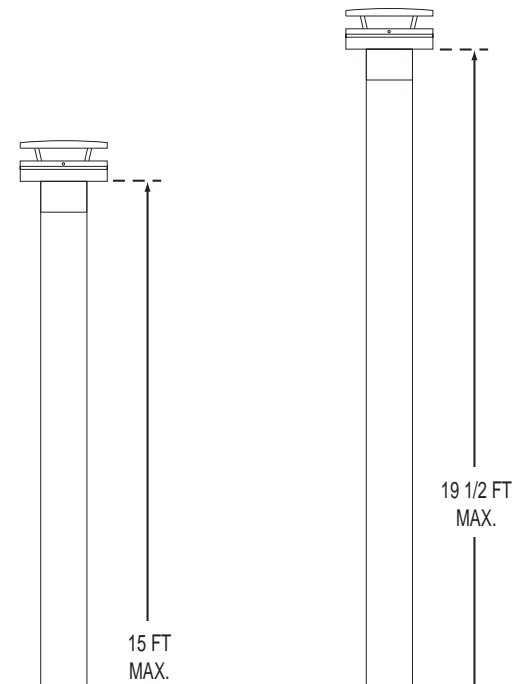
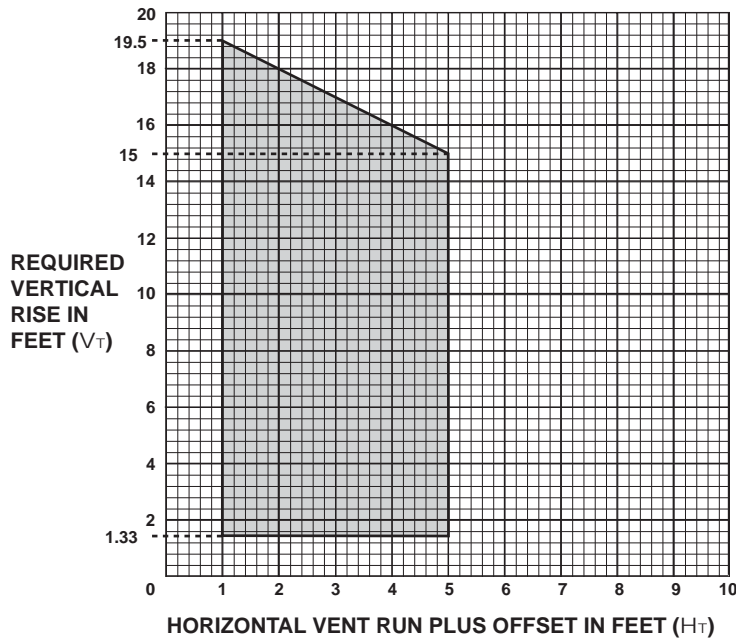

3.0 INSTALLATION

! WARNING
FOLLOW THE VENTING INSTRUCTIONS EXACTLY.
ALL INNER EXHAUST AND OUTER INTAKE VENT PIPE JOINTS MAY BE SEALED USING EITHER RED RTV HIGH TEMP SILICONE SEALANT W573-0002 (NOT SUPPLIED) OR BLACK HIGH TEMP MILL PAC W573-0007 (NOT SUPPLIED) WITH THE EXCEPTION OF THE APPLIANCE EXHAUST FLUE COLLAR WHICH MUST BE SEALED USING MILL PAC.
IF USING PIPE CLAMPS TO CONNECT VENT COMPONENTS, 3 SCREWS MUST ALSO BE USED TO ENSURE THE CONNECTION CANNOT SLIP OFF.
DO NOT CLAMP THE FLEXIBLE VENT PIPE.
RISK OF FIRE, EXPLOSION OR ASPHYXIATION. IMPROPER SUPPORT OF THE ENTIRE VENTING SYSTEM MAY ALLOW VENT TO SAG AND SEPARATE. USE VENT RUNS SUPPORT AND CONNECT VENT SECTIONS PER INSTALLATION INSTRUCTIONS.
RISK OF FIRE, DO NOT ALLOW LOOSE MATERIALS OR INSULATION TO TOUCH THE VENT PIPE. REMOVE INSULATION TO ALLOW FOR THE INSTALLATION OF THE ATTIC SHIELD AND TO MAINTAIN CLEARANCES TO COMBUSTIBLES.

3.1 WALL AND CEILING PROTECTION

! WARNING
DO NOT FILL THE SPACE BETWEEN THE VENT PIPE AND ENCLOSURE WITH ANY TYPE OF MATERIAL. DO NOT PACK INSULATION OR COMBUSTIBLES BETWEEN CEILING FIRESTOPS. ALWAYS MAINTAIN SPECIFIED CLEARANCES AROUND VENTING AND FIRESTOP SYSTEMS. INSTALL WALL SHIELDS AND FIRESTOPS AS SPECIFIED. FAILURE TO KEEP INSULATION OR OTHER MATERIALS AWAY FROM VENT PIPE MAY CAUSE FIRE.

For clearances to combustible materials from the vent pipe, see "FRAMING" section.

3.2 HORIZONTAL INSTALLATION

! WARNING
THE FIRESTOP ASSEMBLY MUST BE INSTALLED WITH THE VENT SHIELD TO THE TOP.
TERMINALS MUST NOT BE RECESSED INTO A WALL OR SIDING MORE THAN THE DEPTH OF THE RETURN FLANGE OF THE MOUNTING PLATE.

This application occurs when venting through an exterior wall. Having determined the correct height for the air terminal location, cut and frame a hole in the exterior wall as illustrated to accommodate the firestop assembly. Dry fit the firestop assembly before proceeding to ensure the brackets on the rear surface fit to the inside surface of the horizontal framing.

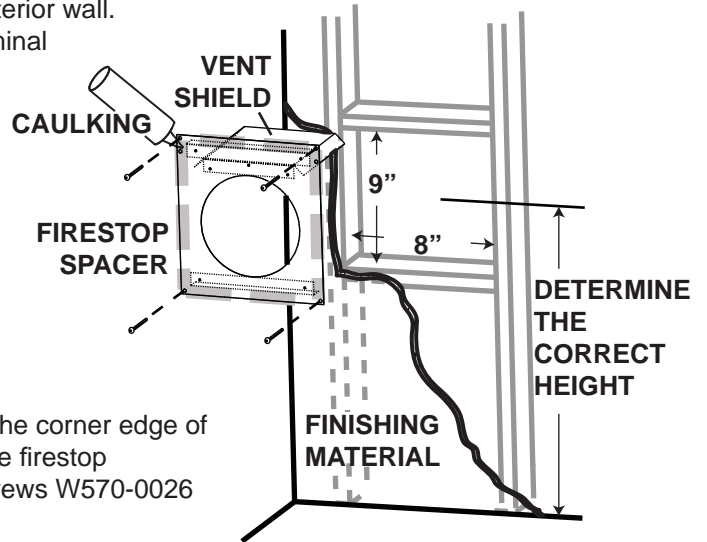

The length of the vent shield may be cut shorter for combustible walls that are less than 8 1/2" thick but the vent shield must extend the full depth of the combustible wall.

- A. Apply a bead of caulking (not supplied) around the corner edge of the inside surface of the firestop assembly, fit the firestop assembly to the hole and secure using the 4 screws W570-0026 (supplied in your manual baggie).
- B. Once the vent pipe is installed in its final position, apply high temperature sealant W573-0007 (not supplied) between the pipe and the firestop.

20.2

3.3 VERTICAL INSTALLATION

! WARNING
IF USING PIPE CLAMPS TO CONNECT VENT COMPONENTS, 3 SCREWS MUST ALSO BE USED TO ENSURE THE CONNECTION CANNOT SLIP OFF.
DO NOT CLAMP THE FLEXIBLE VENT PIPE.
MAINTAIN A MINIMUM 2" SPACE BETWEEN THE AIR INLET BASE AND THE STORM COLLAR.
RISK OF FIRE, EXPLOSION OR ASPHYXIATION. IMPROPER SUPPORT OF THE ENTIRE VENTING SYSTEM MAY ALLOW VENT TO SAG AND SEPARATE. USE VENT RUN SUPPORTS AND CONNECT VENT SECTIONS PER INSTALLATION INSTRUCTIONS.

This application occurs when venting through a roof. Installation kits for various roof pitches are available from your authorized dealer / distributor. See accessories to order specific kits required.

- A. Determine the air terminal location, cut and frame a square opening as illustrated in the ceiling and the roof to provide the minimum 1" clearance between the vent pipe and any combustible material. Try to center the vent pipe location midway between two joists to prevent having to cut them. Use a plumb bob to line up the center of the openings. A vent pipe shield will prevent any materials such as insulation, from filling up the 1" air space around the pipe. Nail headers between the joist for extra support.

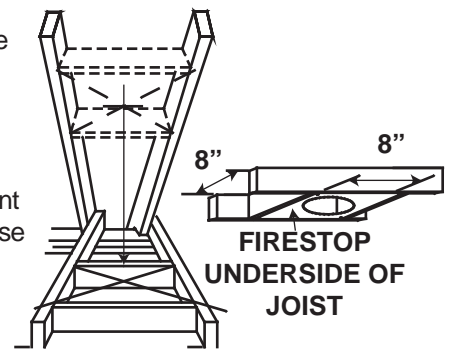

- B. Apply a bead of caulking (not supplied) to the framework or to the Wolf Steel vent pipe shield plate or equivalent (in the case of a finished ceiling), and secure over the opening in the ceiling. A firestop must be placed on the bottom of each framed opening in a roof or ceiling that the venting system passes through. Apply a bead of caulking all around and place a firestop spacer over the vent shield to restrict cold air from being drawn into the room or around the fireplace. Ensure that both spacer and shield maintain the required clearance to combustibles. Once the vent pipe is installed in its final position, apply sealant between the pipe and the firestop assembly.

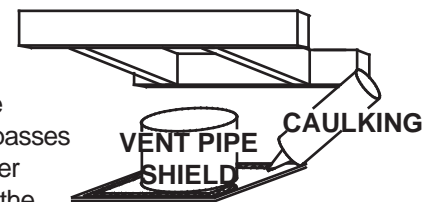

- C. In the attic, slide the vent pipe collar down to cover up the open end of the shield and tighten. This will prevent any materials, such as insulation, from filling up the 1" air space around the pipe.

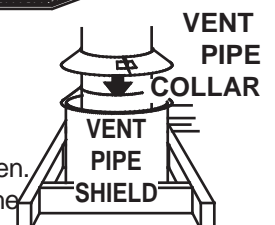

21.1

! WARNING

DO NOT ALLOW THE INNER FLEX PIPE TO BUNCH UP ON HORIZONTAL OR VERTICAL RUNS AND ELBOWS. KEEP IT PULLED TIGHT.

SPACERS ARE ATTACHED TO THE INNER FLEX PIPE AT PREDETERMINED INTERVALS TO MAINTAIN AN EVEN AIR GAP TO THE OUTER FLEX PIPE. THIS GAP IS REQUIRED FOR SAFE OPERATION. A SPACER IS REQUIRED AT THE START, MIDDLE AND END OF EACH ELBOW TO ENSURE THIS GAP IS MAINTAINED. THESE SPACERS MUST NOT BE REMOVED.

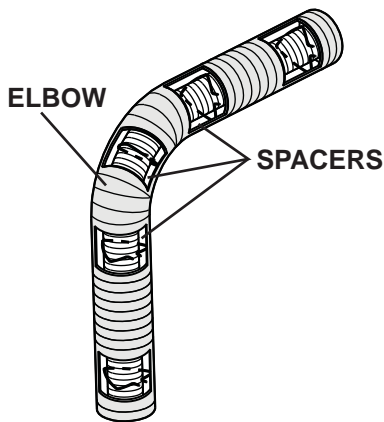

For safe and proper operation of the appliance, follow the venting instructions exactly.

All inner flex pipe and outer flex pipe joints may be sealed using high temperature sealant W573-0002 (not supplied) or the high temperature sealant W573-0007 Mill Pac (not supplied). However, the high temperature sealant W573-0007 Mill Pac (not supplied) must be used on the joint connecting the inner flex pipe and the exhaust flue collar.

Use only approved flexible vent pipe kits marked:



“Wolf Steel Approved Venting” as identified by the stamp only on the outer flex pipe.

22.1

3.4.1 HORIZONTAL AIR TERMINAL INSTALLATION

! WARNING

IF USING PIPE CLAMPS TO CONNECT VENT COMPONENTS, 3 SCREWS MUST ALSO BE USED TO ENSURE THE CONNECTION CANNOT SLIP OFF.

- A. Stretch the inner flex pipe to the required length taking into account the additional length needed for the finished wall surface. Slip the vent pipe a minimum of 2" over the inner sleeve of the air terminal and secure with 3 #8 screws. Apply a heavy bead of the high temperature sealant W573-0007 Mill Pac (not supplied).
- B. Using the outer flex pipe, slide over the outer combustion air sleeve of the air terminal and secure with 3 #8 screws. Seal using high temperature sealant W573-0002 (not supplied).
- C. Insert the vent pipes through the firestop maintaining the required clearance to combustibles. Holding the air terminal (lettering in an upright, readable position), secure to the exterior wall and make weather tight by sealing with caulking (not supplied).
- D. If more vent pipe needs to be used to reach the fireplace, couple them together as illustrated. The vent system must be supported approximately every 3 feet for both vertical and horizontal runs. Use noncombustible strapping to maintain the minimum clearance to combustibles.

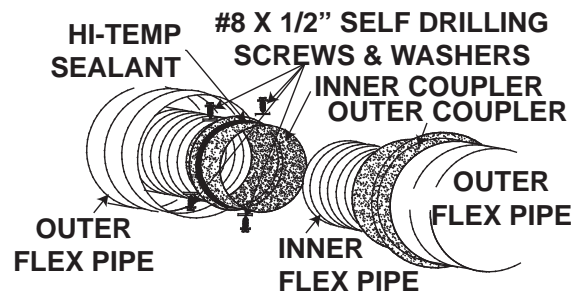
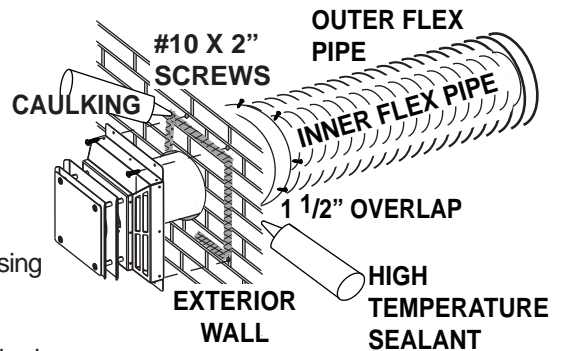

The air terminal mounting plate may be recessed into the exterior wall or siding no greater than the depth of its return flange.

3.4.2 VERTICAL AIR TERMINAL INSTALLATION

! WARNING
IF USING PIPE CLAMPS TO CONNECT VENT COMPONENTS, 3 SCREWS MUST ALSO BE USED TO ENSURE THE CONNECTION CANNOT SLIP OFF.
DO NOT CLAMP THE FLEXIBLE VENT PIPE.
MAINTAIN A MINIMUM 2" SPACE BETWEEN THE AIR INLET BASE AND THE STORM COLLAR.
RISK OF FIRE, EXPLOSION OR ASPHYXIATION. IMPROPER SUPPORT OF THE ENTIRE VENTING SYSTEM MAY ALLOW VENT TO SAG AND SEPARATE. USE VENT RUN SUPPORTS AND CONNECT VENT SECTIONS PER INSTALLATION INSTRUCTIONS.

- A.** Fasten the roof support to the roof using the screws provided. The roof support is optional. In this case the venting is to be adequately supported using either an alternate method suitable to the authority having jurisdiction or the optional roof support.
- B.** Stretch the inner flex pipe to the required length. Slip the inner flex pipe a minimum of 2" over the inner pipe of the air terminal connector and secure with 3 #8 screws. Seal using a heavy bead of high temperature sealant W573-0007 (not supplied).
- C.** Repeat using the outer flex pipe, using a heavy bead of high temperature sealant W573-0002 (not supplied).
- D.** Thread the air terminal connector / vent pipe assembly down through the roof. The air terminal must be positioned vertically and plumb. Attach the air terminal connector to the roof support, ensuring that the top of the air terminal is 16" above the highest point that it penetrates the roof.
- E.** Remove nails from the shingles, above and to the sides of the air terminal connector. Place the flashing over the air terminal connector leaving a min. 3/4" of the air terminal connector showing above the top of the flashing. Slide the flashing underneath the sides and upper edge of the shingles. Ensure that the air terminal connector is properly centred within the flashing, giving a 3/4" margin all around. Fasten to the roof. Do not nail through the lower portion of the flashing. Make weather-tight by sealing with caulking. Where possible, cover the sides and top edges of the flashing with roofing material.
- F.** Aligning the seams of the terminal and air terminal connector, place the terminal over the air terminal connector making sure the vent pipe goes into the hole in the terminal. Secure with the three screws provided.
- G.** Apply a heavy bead of weatherproof caulking 2" above the flashing. Install the storm collar around the air terminal and slide down to the caulking. Tighten to ensure that a weather-tight seal between the air terminal and the collar is achieved.
- H.** If more vent pipe needs to be used to reach the appliance see "HORIZONTAL AIR TERMINAL INSTALLATION" section.

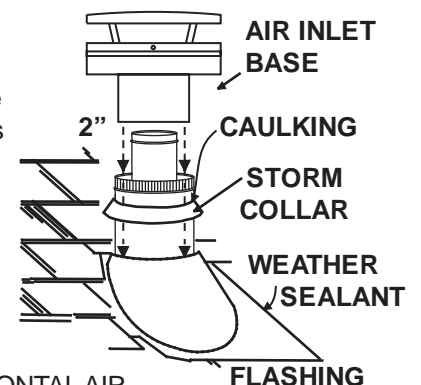
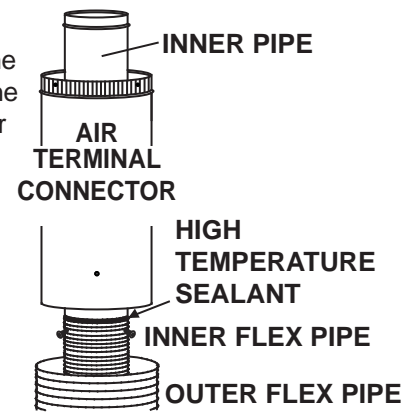
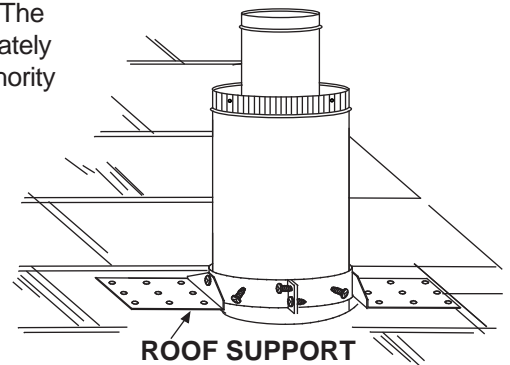

3.4.3 APPLIANCE VENT CONNECTION

- A.** Install the inner flex pipe to the fireplace. Secure with 3 screws and flat washers. Seal the joint and screw holes using the high temperature sealant W573-0007 (not supplied).
- B.** Install the outer flex pipe to the fireplace. Attach and seal the joints using the high temperature sealant W573-0002 (not supplied).

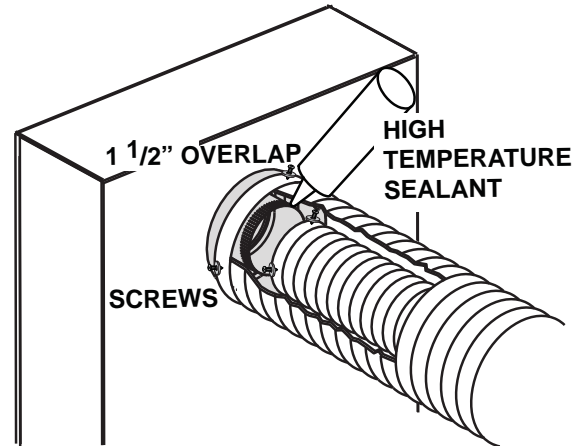

28.4

3.5 MOBILE HOME

This appliance is certified to be installed as an OEM (Original Equipment Manufacturer) installation in a manufactured home or mobile home and must be installed in accordance with the manufacturer's instructions and the Manufactured Home Construction and Safety Standard, Title 24 CFR, Part 3280, in the United States or the Mobile Home Standard, CAN/CSA Z240 MH Series, in Canada. This appliance is only for use with the type(s) of gas indicated on the rating plate. A conversion kit is supplied with the mobile home appliance.

This Mobile/Manufactured Home Listed appliance comes factory equipped with a means to secure the unit. For mobile home installations, the appliance must be fastened in place. It is recommended that the appliance be secured in all installations. Always turn off the pilot and the fuel supply at the source, prior to moving the mobile home. After moving the mobile home and prior to lighting the appliance, ensure that the logs are positioned correctly.

This appliance is certified to be installed in an aftermarket permanently located, manufactured (mobile) home, where not prohibited by local codes.

This appliance is only for use with the type of gas indicated on the rating plate. This appliance is not convertible for use with other gases, unless a certified kit is used.

Conversion Kits

This appliance is field convertible between Natural Gas (NG) and Propane (LP).

To convert from one gas to another consult your Authorized dealer/distributor.

29.3

3.6 GAS INSTALLATION

! WARNING
RISK OF FIRE, EXPLOSION OR ASPHYXIATION. ENSURE THERE ARE NO IGNITION SOURCES SUCH AS SPARKS OR OPEN FLAMES.
SUPPORT GAS CONTROL WHEN ATTACHING GAS SUPPLY PIPE TO PREVENT DAMAGING GAS LINE.
ALWAYS LIGHT THE PILOT WHETHER FOR THE FIRST TIME OR IF THE GAS SUPPLY HAS RUN OUT WITH THE GLASS DOOR OPENED OR REMOVED. PURGING OF THE GAS SUPPLY LINE SHOULD BE PERFORMED BY A QUALIFIED SERVICE TECHNICIAN. ASSURE THAT A CONTINUOUS GAS FLOW IS AT THE BURNER BEFORE CLOSING THE DOOR. ENSURE ADEQUATE VENTILATION. FOR GAS AND ELECTRICAL LOCATIONS, SEE "DIMENSION" SECTION.
ALL GAS CONNECTIONS MUST BE CONTAINED WITHIN THE APPLIANCE WHEN COMPLETE.
HIGH PRESSURE WILL DAMAGE VALVE. DISCONNECT GAS SUPPLY PIPING BEFORE TESTING GAS LINE AT TEST PRESSURES ABOVE 1/2 PSIG.
VALVE SETTINGS HAVE BEEN FACTORY SET, DO NOT CHANGE.

Proceed once the vent installation is complete. Installation and servicing to be done by a qualified installer
Do not use open flame.

- 3.6.1** Move the appliance into position and secure.
- 3.6.2** If equipped with a flex connector the appliance is designed to accept a 1/2" gas supply. Without the connector it is designed to accept a 3/8" gas supply. The appliance is equipped with a manual shut off valve to turn off the gas supply to the appliance.
- 3.6.3** Connect the gas supply in accordance to local codes. In the absence of local codes, install to the current CAN/CSA-B149.1 Installation Code in Canada or to the current National Fuel Gas Code, ANSI Z223.1 / NFPA 54 in the United States.
- 3.6.4** When flexing any gas line, support the gas valve so that the lines are not bent or kinked.
- 3.6.5** Check for gas leaks by brushing on a soap and water solution.

30.1

3.7 ELECTRICAL CONNECTION

! WARNING
RISK OF ELECTRIC SHOCK! CONTROL AND VALVE OPERATE WITH 110V.
DO NOT USE THE APPLIANCE IF ANY PART HAS BEEN UNDER WATER. CALL A QUALIFIED SERVICE TECHNICIAN IMMEDIATELY TO HAVE THE APPLIANCE INSPECTED FOR DAMAGE TO THE ELECTRICAL CIRCUIT.

3.8 HARD WIRING CONNECTION

It is necessary to hard wire this appliance.

Permanently framing the appliance with an enclosure, requires the appliance junction box to be hard wired. This appliance must be electrically connected and grounded in accordance with local codes. In the absence of local codes, use the current CSA C22.1 CANADIAN ELECTRICAL CODE in Canada or the ANSI/NFPA 70-1996 NATIONAL ELECTRICAL CODE in the United States.

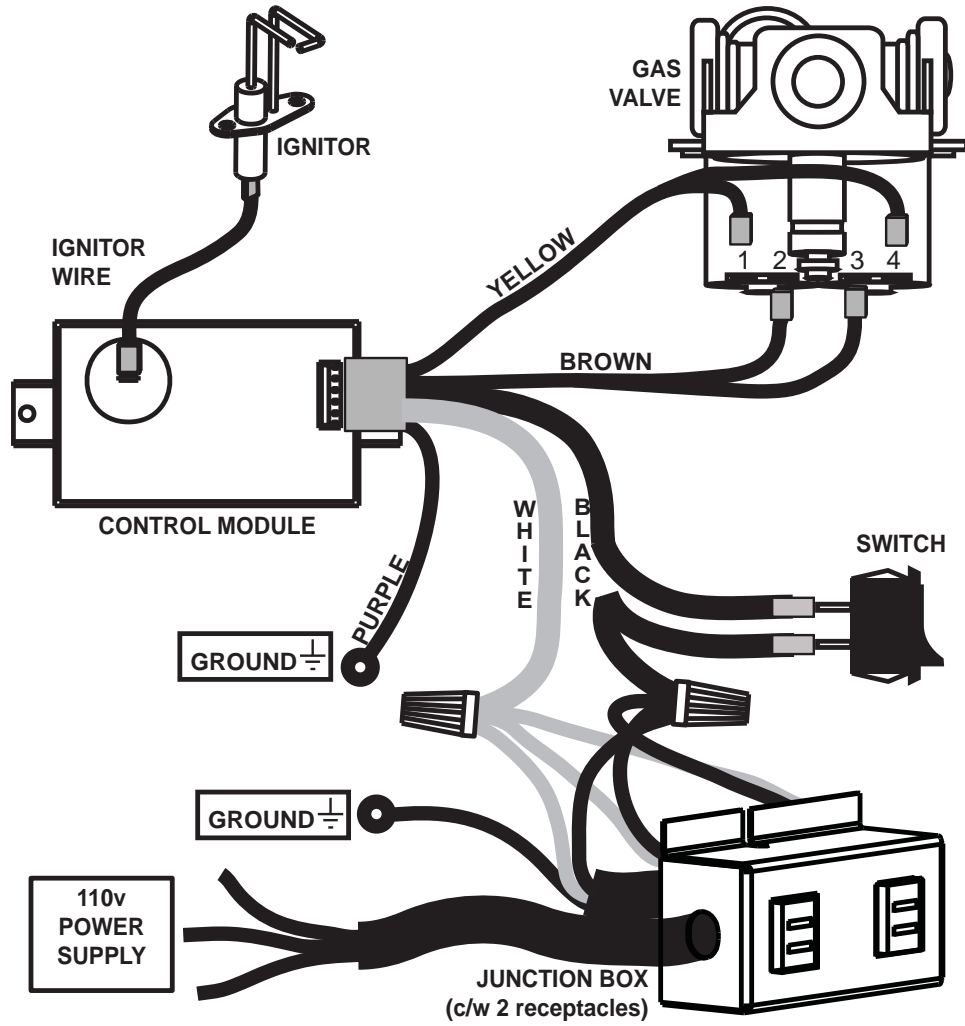

3.9 STAND-OFF ASSEMBLY

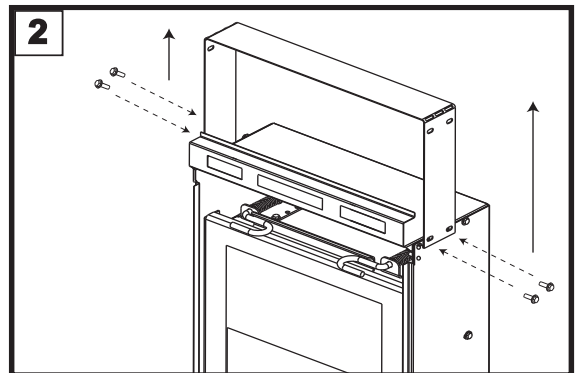
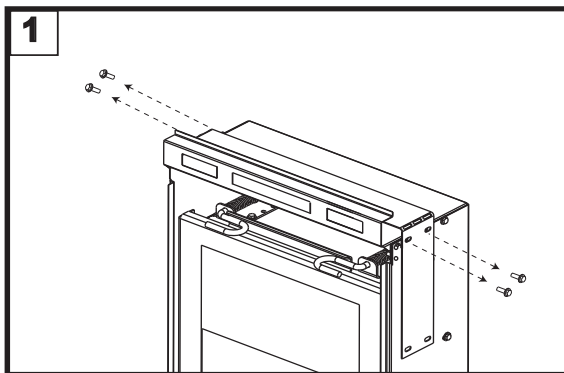

3.10 NAILING TAB INSTALLATION

Attach the 4 nailing tabs supplied to the sides of the outer shell as illustrated using the 8 self-tapping screws included in the manual baggie.

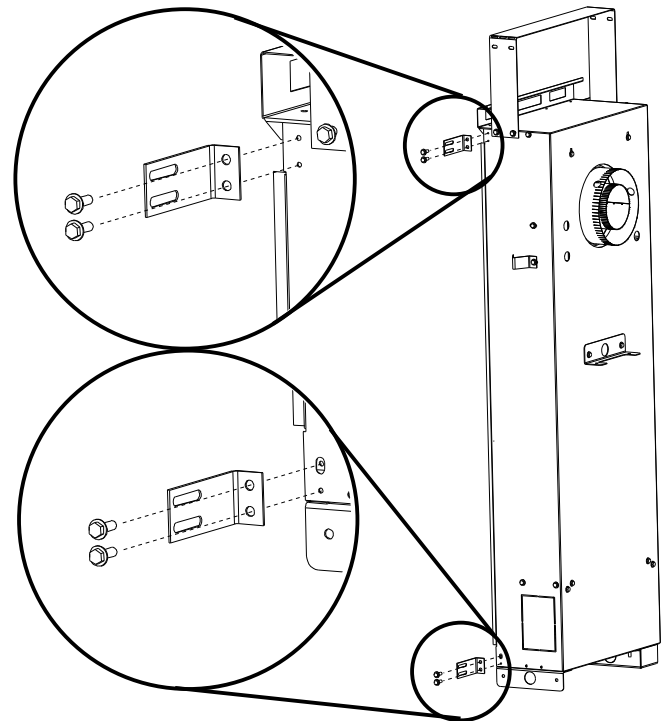

3.11 FRAMING

! WARNING

IN ORDER TO AVOID THE POSSIBILITY OF EXPOSED INSULATION OR VAPOUR BARRIER COMING IN CONTACT WITH THE APPLIANCE BODY, IT IS RECOMMENDED THAT THE WALLS OF THE APPLIANCE ENCLOSURE BE "FINISHED" (IE: DRYWALL / SHEETROCK), AS YOU WOULD FINISH ANY OTHER OUTSIDE WALL OF A HOME. THIS WILL ENSURE THAT CLEARANCE TO COMBUSTIBLES IS MAINTAINED WITHIN THE CAVITY.

DO NOT NOTCH THE FRAMING AROUND THE APPLIANCE STAND-OFFS. FAILURE TO MAINTAIN AIR SPACE CLEARANCE MAY CAUSE OVER HEATING AND FIRE. PREVENT CONTACT WITH SAGGING OR LOOSE INSULATION OR FRAMING AND OTHER COMBUSTIBLE MATERIALS. BLOCK OPENING INTO THE CHASE TO PREVENT ENTRY OF BLOWN-IN INSULATION. MAKE SURE INSULATION AND OTHER MATERIALS ARE SECURED.

The TORCH has been designed to be installed mid-way up a wall. If installing this appliance close to the finished floor, the appliance must be raised a minimum of 2" (unobstructed) to allow for full rotation of the control door. It is not necessary to install floor protection.

Although the appliance fits between studs, most jurisdictions will not allow a "hole" in the warm air envelope of a residential structure. It is recommended to build either an interior or exterior chase with a minimum depth of 7".

It is best to frame your appliance after it is positioned and the vent system is installed. Frame to local building codes.

To install the appliance face flush with the finished surface, position the framework to accommodate the thickness of the finished surface. Use 4 flat-head screws to secure the nailing tabs to the framing. Cover the nailing tabs with your finishing material.

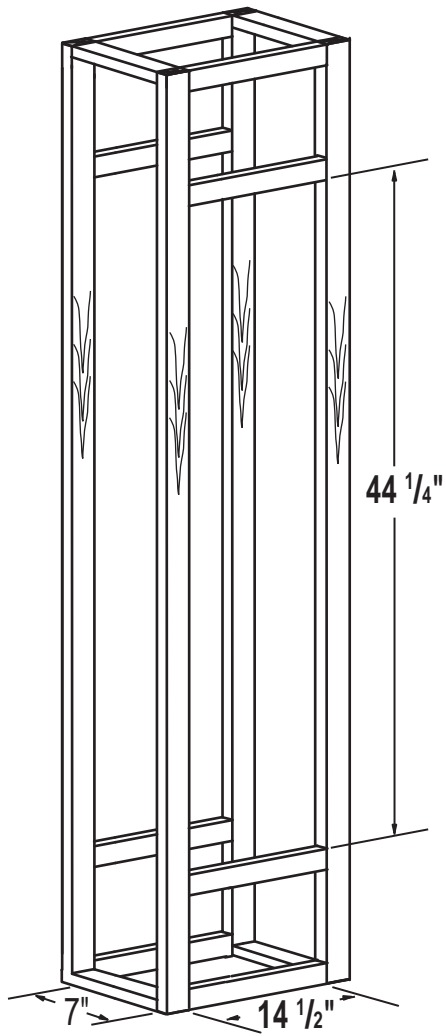
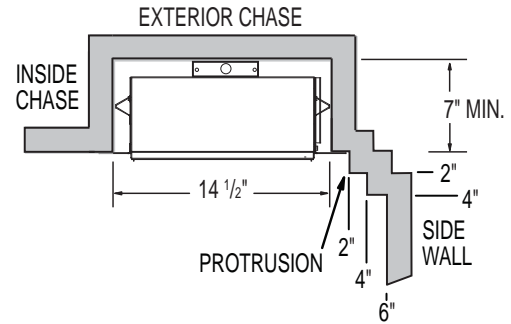
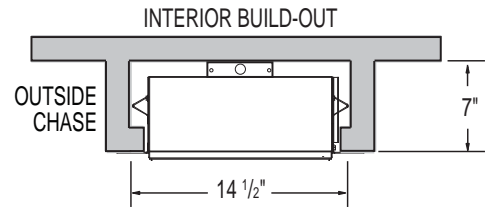
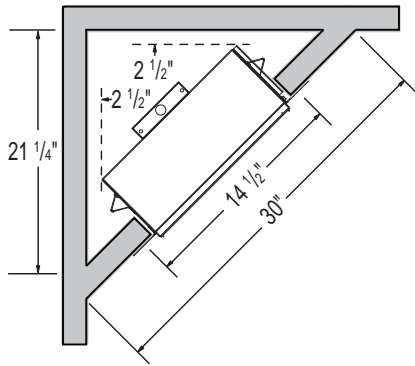

1

FRAMING OPENING DIMENSIONS

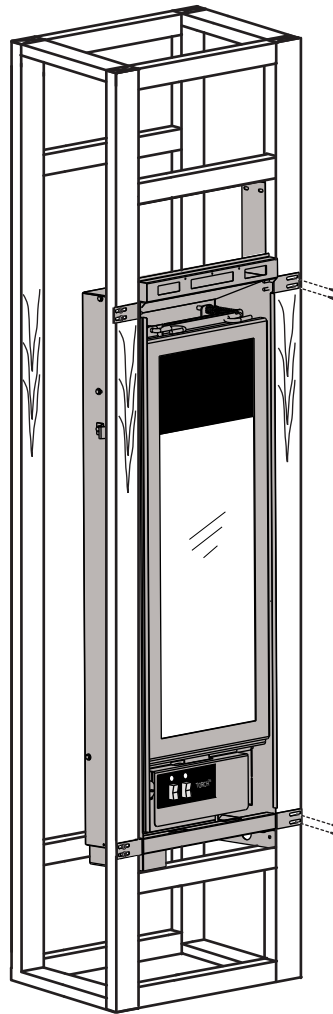

2

INSTALLATION

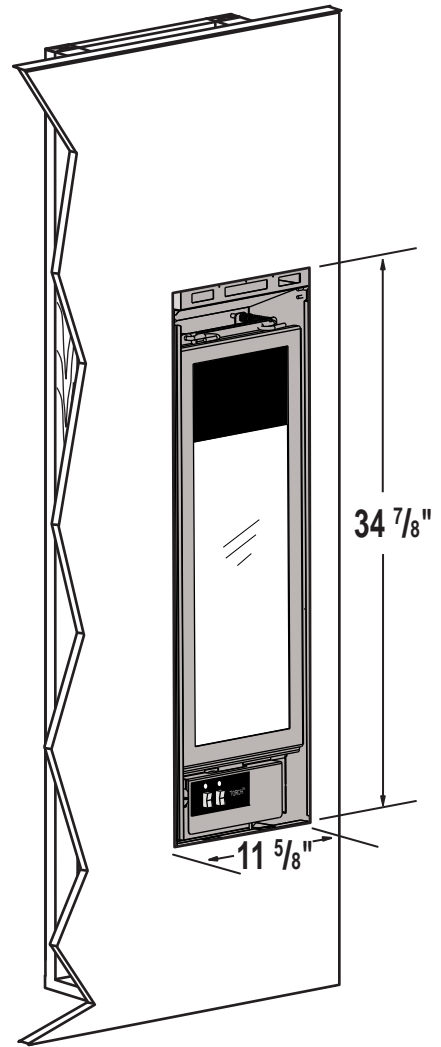

3

FINISHING OPENING DIMENSIONS

NOTE: Finished opening is smaller than the framed opening.

3.12 MINIMUM CLEARANCE TO COMBUSTIBLES

Minimum clearance to combustible construction from appliance and vent surfaces:

- Appliance framing:**
 - 6" to top
 - 0" to stand-offs (Rear and sides)
- Vent pipe*:**
 - 2" top
 - 1" sides and bottom
- Recessed depth:**
 - 7"

* **HORIZONTAL VENT SECTIONS:** A minimum clearance of 1" at the bottom and sides and 2" at the top of the vent pipe in all horizontal runs to combustibles is required. Use firestop spacer W010-1961 (supplied).

* **VERTICAL VENT SECTIONS:** A minimum of 1" all around the vent pipe on all vertical runs to combustibles is required. Use firestop spacer W500-0358 (not supplied).

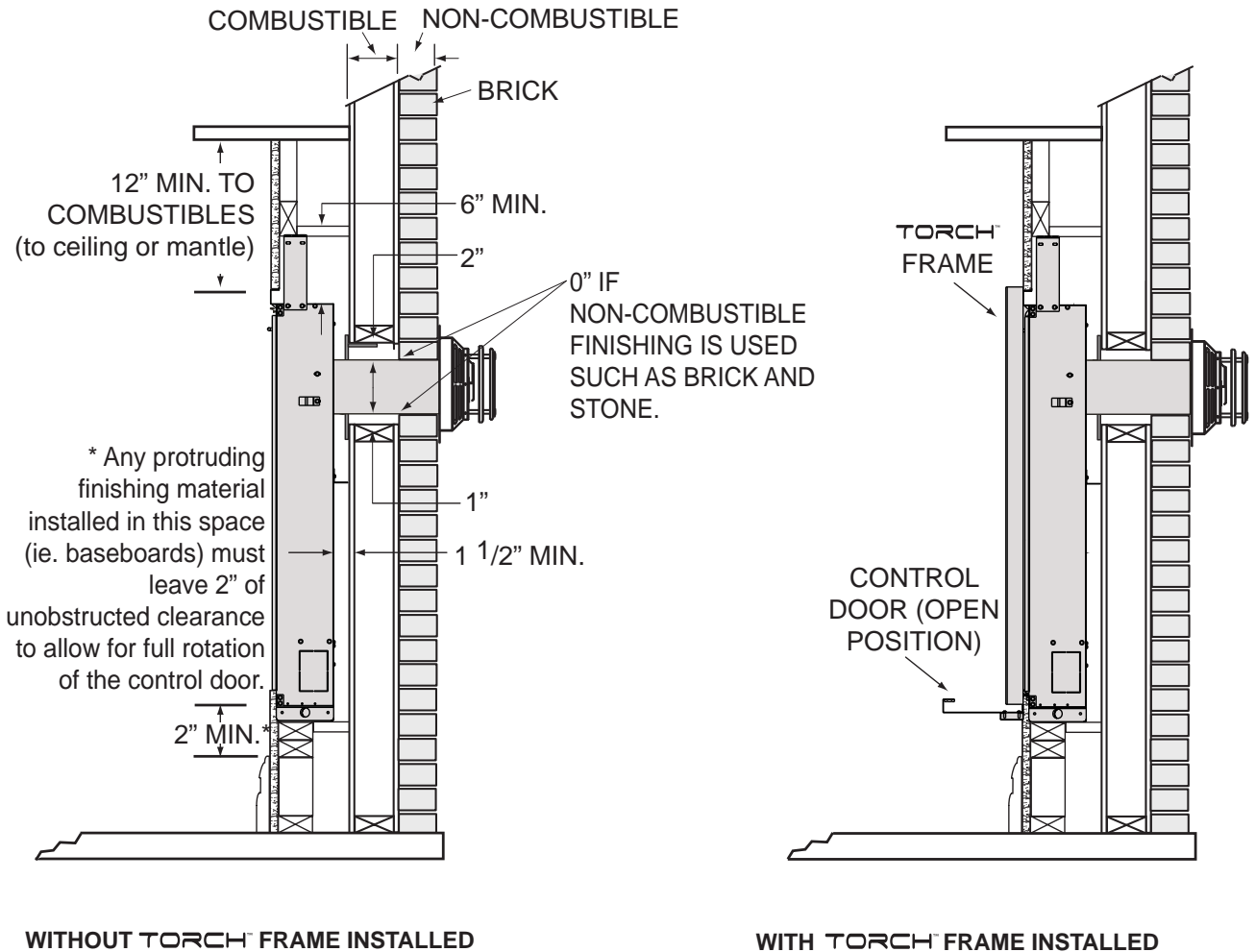

4.0 FINISHING

4.1 MOUNTING CABINET INSTALLATION

! WARNING

BEFORE STARTING THE INSTALLATION REMOVE THE PROTECTIVE LAYER FROM ALL THREE COMPONENTS THAT MAKE UP THE GT8 (CABINET, FRAME, AND TORCH)

NOTE: It is recommended that all fasteners be stainless steel.

4.1.1 Using the installation template (W122-0401) supplied with the TMCK or TMCSS kit, determine the best mounting location for your new Torch. See "MINIMUM CLEARANCE TO COMBUSTIBLES" section. Mark all 14 hole centres on the wall (surface) using the template.

4.1.2 Remove the template. Depending on the surface and fasteners, drill the appropriate holes. Hold the Torch up, aligning the mounting brackets to the mounting holes. Secure the Torch to the wall using the appropriate fasteners.

NOTE: The Torch has been designed to have a 1/2" clearance between the rear outer panel and the mounting surface.

4.1.3 Start the fasteners into each of the six remaining mounting holes. Align the keyholes of the frame to the heads of the fasteners and slide the frame down onto the fasteners. Ensure the frame is plumb and level before tightening the fasteners.

NOTE: It is recommended that the gas and electrical be connected to the appliance at this stage. Both must enter the appliance at the opening created between the bottom of the Torch and the bottom of the mounting frame.

4.1.4 Slide the front of the cabinet over the mounting frame, ensuring the "mesh" is to the top. Start each of the four screws (supplied) through the slots. Once the cabinet has been adjusted for depth the four screws can be tightened.

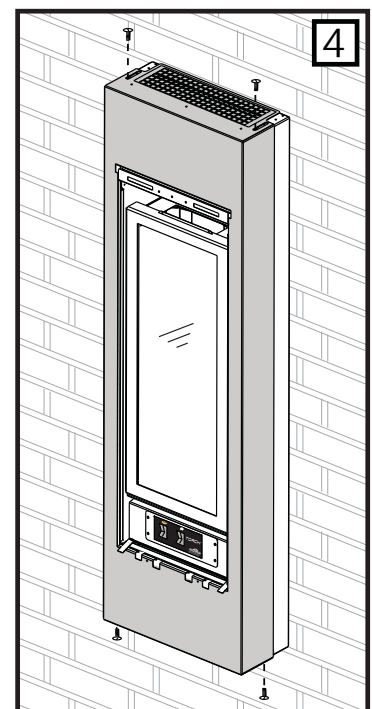
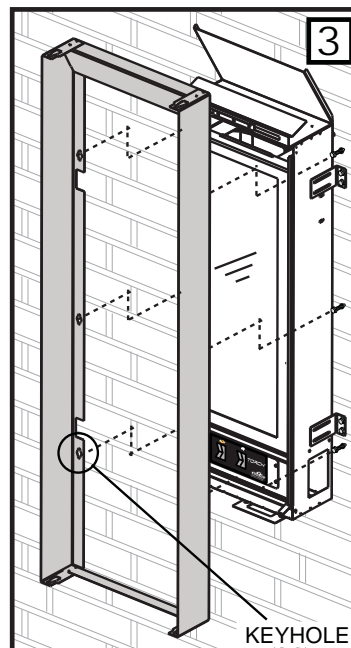
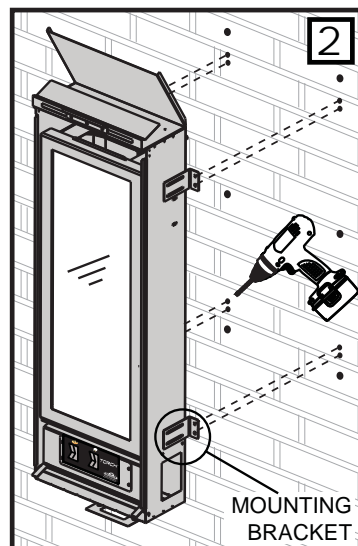
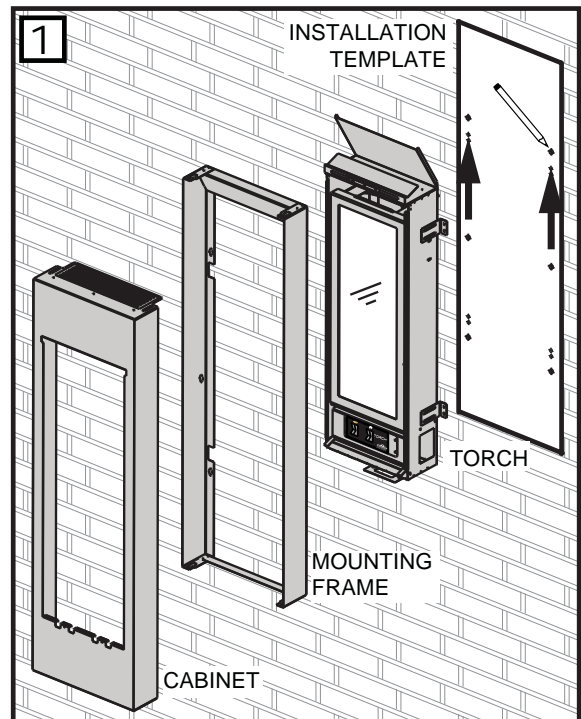

4.2 DOOR REMOVAL

Before the glass door can be removed, the optional frame/front must be removed.

The glass door is secured to the top front edge of the firebox. Pull the handles of the latches forward, then lift the hooks out from the slots in the door frame to release the top of the door. Then, pivot forward until the top edge of the door clears the front of the appliance. Next gripping the sides of the door lift the door out from the retainer along the bottom of the door.

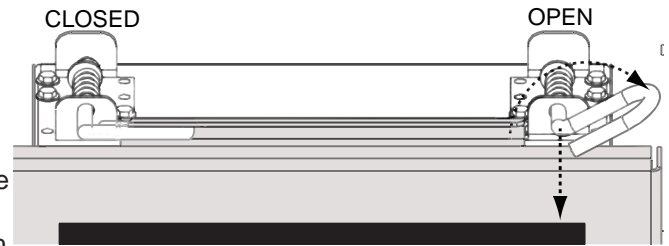

4.3 GLASS REMOVAL

Having removed the door, lay on a smooth flat surface, face down. There are 4 glass retainers that need to be bent away from the glass to release it from the frame. Do not pry on the glass.

When replacing **DO NOT SUBSTITUTE MATERIAL**, replace the gasket (W562-0008) and the glass (W300-0088). Set new glass into the frame and gently bend tabs into the gasket to secure.

NOTE: Care must be taken when removing and disposing of any broken glass or damaged components. Be sure to vacuum up any broken glass from inside the appliance before operation.

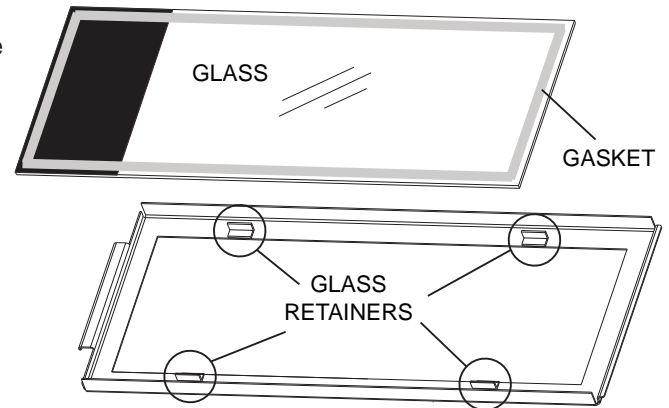

4.4 FRAME/FRONT INSTALLATION

4.4.1 Align the two holes in the upper portion of the hinge on the control door to those in the bottom trim bracket, secure using two of the #8 x 1/2" hex head screws supplied.

4.4.2 Install the top trim bracket to the firebox using the three #9 - 14 x 1/2" hex head screws supplied in the TORCH manual baggie.

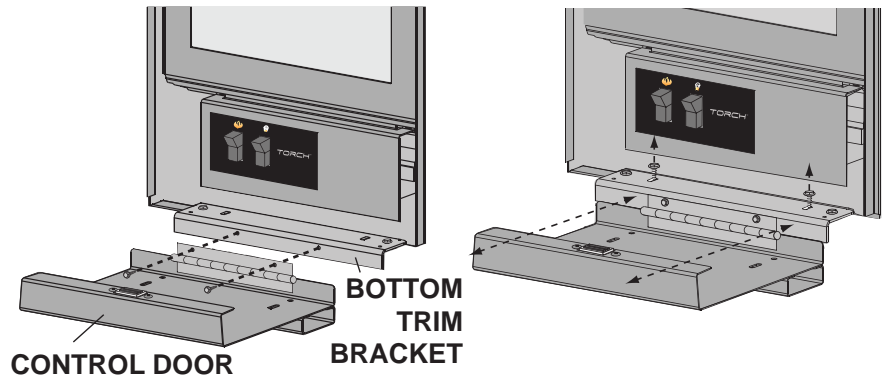

4.4.3 Rest the top lip of the TORCH frame on the top trim bracket, and the securing tabs at the bottom of the TORCH frame on the bottom trim bracket.

4.4.4 Align the two slots in the top of the TORCH frame with the two holes in the top trim bracket and secure using the two #10 pan head screws supplied however do not fully tighten to leave room for adjustment.

4.4.5 Align the holes in the securing tabs at the bottom of the TORCH frame with the holes in the bottom trim bracket and secure using the two remaining #8 x 1/2" hex head screws, however do not fully tighten to leave room for adjustment.

4.4.6 If required, the bottom trim bracket can be adjusted by loosening its securing screws.

- 4.4.7 Once the TORCH[®] frame is perfectly square and the control door will close without rubbing against the sides of the TORCH[®] frame, tighten all screws.
- 4.4.8 Open the control door.
- 4.4.9 Insert the door stop chain into the receiving slot in the control door.
- 4.4.10 Insert the door stop chain into the receiving slot in the TORCH[®] frame so that when fully open the control door has a clearance of 1/8" to the finished wall. **NOTE: In most cases, a count of 9 balls between receiving slots will give the desired clearance.**
- 4.4.11 Close the control door.

The TORCH[®] frame has been designed to accommodate finished material thicknesses of .500" - .750". If it is necessary to pull the TORCH[®] frame out to the max. .750" the magnetic catch will need to be adjusted. Minor adjustment can be made by removing shims from behind the magnet. Major adjustments can be made by moving the magnet to the outside of the panel.

Adjustment may be required to accommodate the door stop chain slack when the control door is closed. The control door securing screws can be loosened to allow adjustment. Before re-tightening the screws ensure the control door is still recessed into the TORCH[®] frame at a similar offset to the top trim piece.

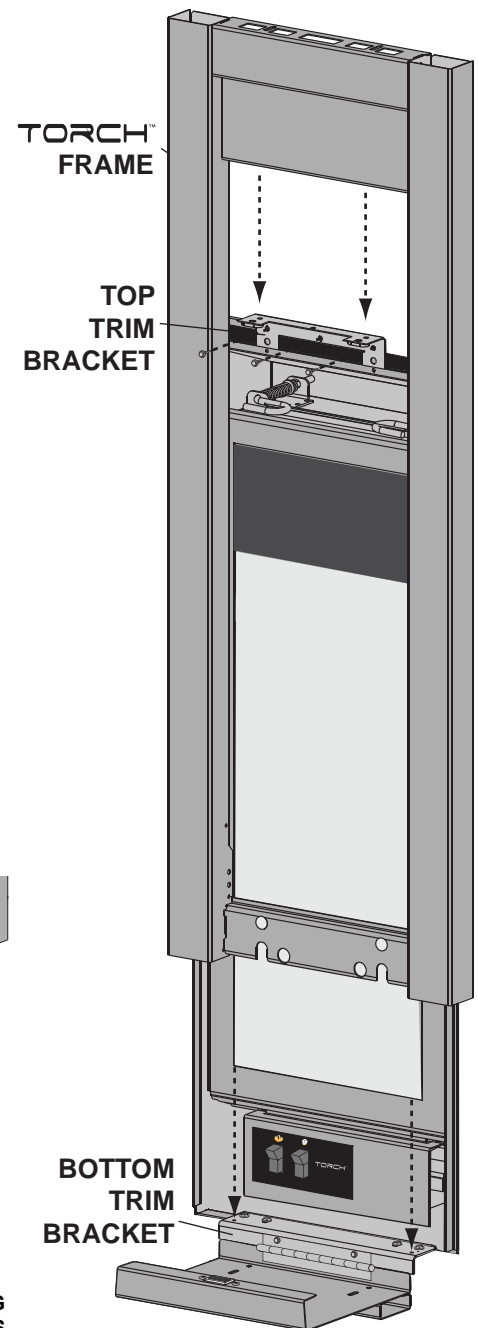
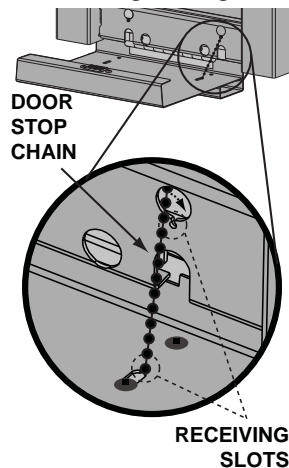

4.5 ACCENT GLASS INSTALLATION

Carefully sprinkle the accent glass onto the glass support evenly. Ensure no glass falls into the burner area. If this happens, insert a clean bag into your vacuum cleaner and vacuum out the accent glass. Replacement accent glass can be purchased from Wolf Steel Ltd.



4.6 LK8 LIGHT INSTALLATION (OPTIONAL)

- 4.6.1 Turn off the electrical and gas supply to the appliance.
- 4.6.2 Remove the frame from the appliance by removing the 2 black securing screws from the top, and the 2 silver hex head securing screws from the bottom.
- 4.6.3 Lay the frame down on its front, being careful not to scratch the finish.
- 4.6.4 Starting at the top of the frame, take one light assembly and carefully snap it into place in the hole provided. Repeat for each of the light assemblies. The wires on the top 2 light assemblies will need to be fed in behind the heat shields.

NOTE: When installing the light kit be careful not to scratch your fingers on any of the exposed screws in the frame.

- 4.6.5 Using illustration as a guide, connect the light assemblies to the appropriate flags on the wire harness. The wire harness is labeled (TR) top right, (BR) bottom right (TL) Top left and (BL) bottom left.
- 4.6.6 Secure the wires into the clips at both sides and the bottom of the frame. Use the extra clips provided to retain any loose wires.
- 4.6.7 Re-attach frame onto appliance.
- 4.6.8 Remove the control panel by removing the 2 screws securing it along the top edge. Leave the wires connected to the ON/OFF switch.
- 4.6.9 Place the transformer into the bottom of the appliance. Plug the transformer into the receptacle.
- 4.6.10 Lay the control panel flat along the bottom edge of the frame. Attach one of the wire leads from the transformer to the lead on the wire harness labeled "TRANS", and the other to the ON/OFF switch. Attach the last lead on the wire harness labeled "SWI" to the ON/OFF switch.
- 4.6.11 Re-secure the control panel.
- 4.6.12 Turn on the gas supply and electrical power.

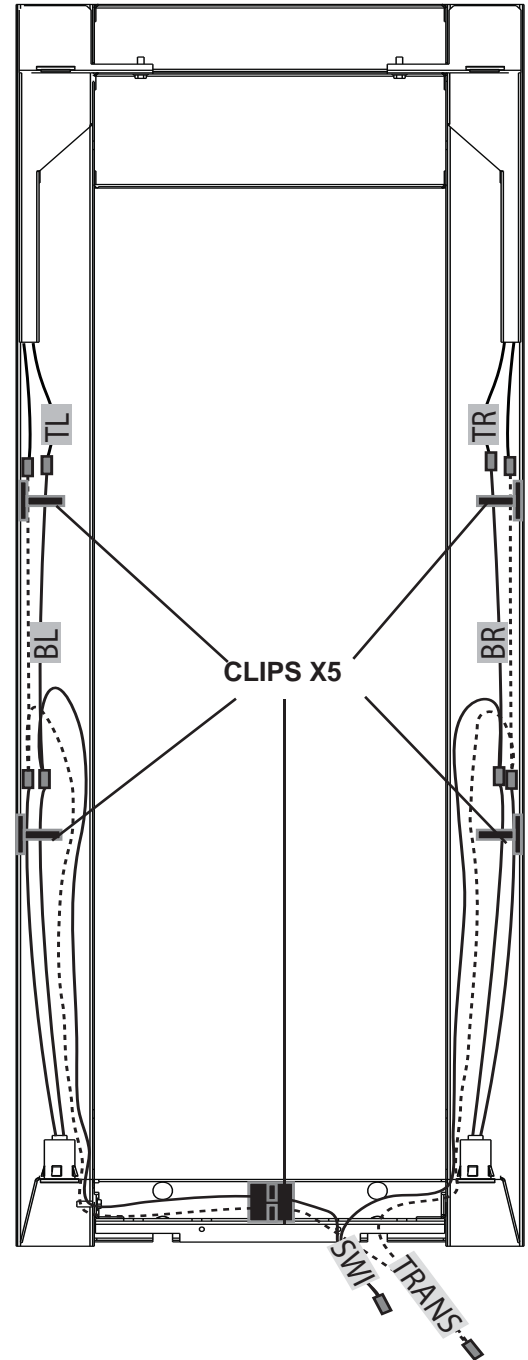

5.0 OPERATION

! WARNING

IF YOU DO NOT FOLLOW THESE INSTRUCTIONS EXACTLY, A FIRE OR EXPLOSION MAY RESULT CAUSING PROPERTY DAMAGE, PERSONAL INJURY OR LOSS OF LIFE.

ALWAYS LIGHT THE PILOT WHETHER FOR THE FIRST TIME OR IF THE GAS SUPPLY HAS RUN OUT WITH THE GLASS DOOR OPENED OR REMOVED.

Assure that a continuous gas flow is at the burner before installing the door. When lit for the first time, the fireplace will emit an odor for a few hours. This is a normal temporary condition caused by the “burn-in” of paints and lubricants used in the manufacturing process and will not occur again. After extended periods of non-operation such as following a vacation or a warm weather season, the fireplace may emit a slight odor for a few hours. This is caused by dust particles in the heat exchanger burning off. In both cases, open a window to sufficiently ventilate the room.

FOR YOUR SAFETY READ BEFORE LIGHTING:

- A.** This fireplace is equipped with an ignition device which automatically lights the pilot. Do not try to light by hand.
- B.** Before operating smell all around the fireplace area for gas and next to the floor because some gas is heavier than air and will settle on the floor.
- C.** Do not use this fireplace if any part has been under water. Immediately call a qualified service technician to inspect the fireplace and replace any part of the control system and any gas control which has been under water.

WHAT TO DO IF YOU SMELL GAS:

- Turn off all gas to the fireplace.
- Open windows.
- Do not try to light any appliance.
- Do not touch any electric switch; do not use any phone in your building.
- Immediately call your gas supplier from a neighbour’s phone. Follow the gas supplier’s instructions.
- If you cannot reach your gas supplier, call the fire department.

LIGHTING INSTRUCTIONS:

1. Stop! Read the above safety information on this label.
2. Turn off all electrical power to the fireplace.
3. This fireplace is equipped with an ignition device which automatically lights the pilot. Do not try to light the pilot by hand.
4. Open the glass door.
5. Wait five (5) minutes to clear out any gas. If you smell gas including near the floor, STOP! Follow “B” in the above safety information on this label. If you don’t smell gas go to the next step.
6. Close the glass door.
7. Turn on all electric power to the fireplace and re-install batteries into the transmitter.
8. Turn the fireplace switch to the ON position.
9. If fireplace will not operate, follow instructions “To Turn Off Gas” and call your service technician or gas supplier.

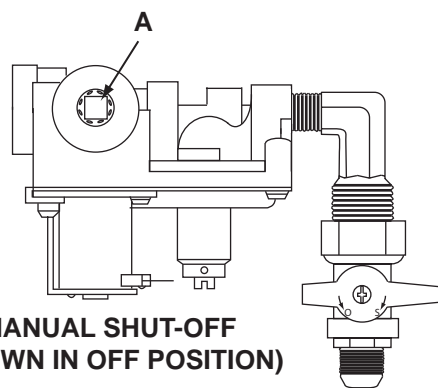

**MANUAL SHUT-OFF
(SHOWN IN OFF POSITION)**

TO TURN OFF GAS:

1. Turn the fireplace switch to the OFF position.
2. Turn off all electrical power to the fireplace if service is to be performed.
3. Turn manual shut-off valve clockwise to off. Do not force.

6.0 RATING PLATE

RATING LABEL LOCATION: THE RATING LABEL IS LOCATED UNDER THE CONTROL PANEL AND IS CHAINED TO THE APPLIANCE. DO NOT REMOVE.

 REFERENCE #15901	CERTIFIED UNDER : CSA 2.22-2007, ANSI 21.50-2007 VENTED GAS FIREPLACE DIRECT VENT GAS FIREPLACE. APPROVED FOR BEDROOM, BATHROOM AND BED SITTING ROOM INSTALLATION. SUITABLE FOR MOBILE HOME INSTALLATION IF INSTALLED IN ACCORDANCE WITH THE CURRENT STANDARD CAN/CSA Z240MH SERIES GAS EQUIPPED MOBILE HOMES. IN CANADA OR IN THE UNITED STATES THE MANUFACTURED HOME CONSTRUCTION AND SAFETY STANDARD. TITLE 24 DFR, PART 3280. WHEN THIS US STANDARD IS NOT APPLICABLE USE THE STANDARD FOR FIRE SAFETY CRITERIA FOR MANUFACTURED HOME INSTALLATIONS, SITES AND COMMUNITIES, ANSI/NFPA 501A.	
	MODEL GT8N ■ (NATURAL GAS) 0-4500FT (0-1370m) 6,000 BTU/h #56	CERTIFIED FOR CANADA AND USA ALTITUDE INPUT ORIFICE
WARNING: DO NOT ADD ANY MATERIAL TO THE APPLIANCE, WHICH WILL COME IN CONTACT WITH THE FLAMES, OTHER THAN THAT SUPPLIED BY THE MANUFACTURER WITH THE APPLIANCE. MINIMUM CLEARANCES TO COMBUSTIBLE MATERIALS TOP 6" RECESSED DEPTH 7" FLOOR 0" VENT 1" SIDES 0" BACK 1 1/2" TOP, SIDES & BACK AS PER ABOVE. FOR FINISHING MATERIAL, SEE OWNERS MANUAL. ELECTRICAL RATING: 115v 0.82AMP, 60HZ MINIMUM AND MAXIMUM HORIZONTAL VENT LENGTHS ARE 10 INCHES AND 10 FEET RESPECTIVELY. MINIMUM AND MAXIMUM VERTICAL VENT LENGTHS ARE 36 INCHES AND 10 FEET RESPECTIVELY.	MANIFOLD PRESSURE: 3.5" WATER COLUMN MANIFOLD PRESSURE: 10" WATER COLUMN MINIMUM SUPPLY PRESSURE: 4.5" WATER COLUMN MINIMUM SUPPLY PRESSURE: 11" WATER COLUMN MAXIMUM SUPPLY PRESSURE: 7.0" WATER COLUMN MAXIMUM SUPPLY PRESSURE: 13" WATER COLUMN VENTED GAS FIREPLACE NOT FOR USE WITH SOLID FUEL. FOR USE WITH GLASS DOOR. CERTIFIED WITH THIS UNIT ONLY. THE APPLIANCE MUST BE VENTED USING THE APPROPRIATE NAPOLEON VENT KITS. SEE OWNERS INSTALLATION MANUAL FOR VENTING SPECIFICS. PROPER REINSTALLATION AND RESEALING IS NECESSARY AFTER SERVICING THE VENT-AIR INTAKE SYSTEM. THIS APPLIANCE IS ONLY FOR USE WITH THE TYPE OF GAS INDICATED ON THE RATING PLATE AND MY BE INSTALLED IN AN AFTERMARKET, PERMANENTLY LOCATED, MANUFACTURED HOME (USA ONLY) OR MOBILE HOME WHERE NOT PROHIBITED BY LOCAL CODES. SEE OWNER'S MANUAL FOR DETAILS. THIS APPLIANCE IS NOT CONVERTIBLE FOR USE WITH OTHER GASES, UNLESS A CERTIFIED KIT IS USED.	
	MADE IN CANADA WOLF STEEL LTD, BARRIE, ON, CANADA SERIAL NUMBER: GT8 ██████████ W385-0381 / A	

7.0 ADJUSTMENTS

7.1 GAS PRESSURE ADJUSTMENT

Outlet pressure can be adjusted if not measuring 3.5" W.C. (NG) or 10.0" W.C. (LP).

- 7.1.1 Pressure can be checked by removing cap (A) using a 3/16 Allen key and replacing it with a 1/8 NPT barb fitting.
- 7.1.2 Place pressure gauge tube over the fitting.
- 7.1.3 Pressure can be adjusted by removing cap (B) using a flat screwdriver, and adjusting the nylon plug with the same screw driver. Turning the plug in (clockwise) will increase the pressure.

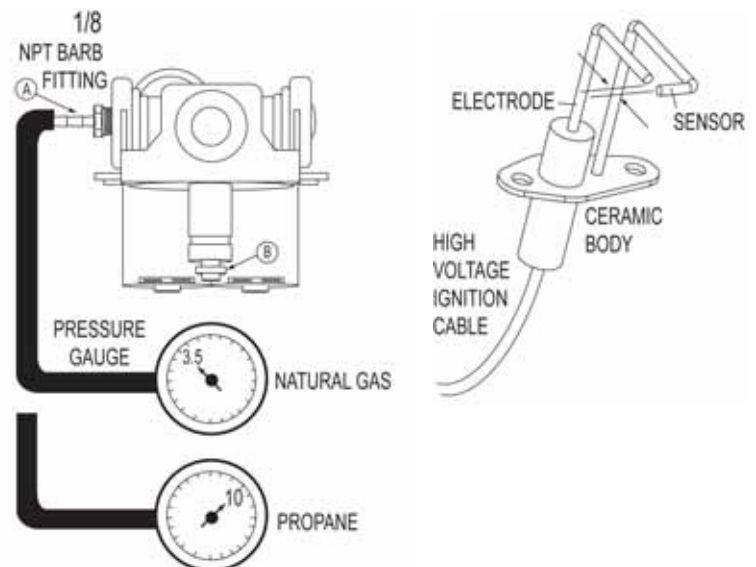

7.2 VENTURI ADJUSTMENT

This model has an air shutter that has been factory set open according to the chart below:

Closing the air shutter will cause a more yellow flame, but can lead to carboning. Opening the air shutter will cause a more blue flame, but can cause flame lifting from the burner ports. The flame may not appear yellow immediately; allow 15 to 30 minutes for the final flame color to be established.

AIR SHUTTER ADJUSTMENT MUST ONLY BE DONE BY A QUALIFIED INSTALLER!

NOTE: It is important that the venturi sits down tight on the orifice. The burner is adjustable up/down to ensure this.

AIR SHUTTER OPENINGS	
LP	5/16" DIA (x2)
NG	3/16" DIA (x1)

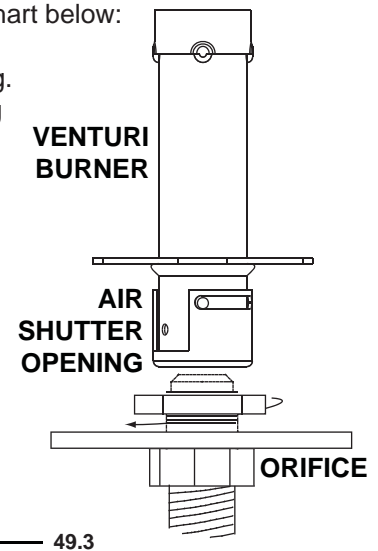

7.3 FLAME CHARACTERISTICS

It is important to periodically perform a visual check of the burner flame. Compare them to the illustration provided.

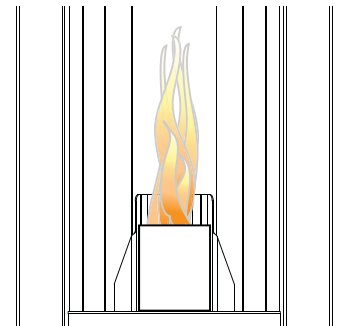

8.0 MAINTENANCE

! WARNING

TURN OFF THE GAS AND ELECTRICAL POWER BEFORE SERVICING THE APPLIANCE.

CAUTION: Label all wires prior to disconnection when servicing controls. Wiring errors can cause improper and dangerous operation. Verify proper operation after servicing. This fireplace and its venting system should be inspected before use and at least annually by a qualified service person. The fireplace area must be kept clear and free of combustible materials, gasoline or other flammable vapors and liquids. The flow of combustion and ventilation air must not be obstructed.

1. In order to properly clean the burner and pilot assembly, remove the logs, rocks and/or glass to expose both assemblies.
2. Keep the control compartment, media, burner, air shutter opening and the area surrounding the logs clean by vacuuming or brushing, at least once a year.
3. Check to see that all burner ports are burning. Clean out any of the ports which may not be burning or are not burning properly.
4. Check to see that the pilot flame is large enough to engulf the flame sensor and/or thermocouple / thermopile as well as reaches the burner.
5. Replace the cleaned logs, rocks or glass. Failure to properly position the media may cause carboning which can be distributed in the surrounding living area.
6. Check to see that the main burner ignites completely on all openings when turned on. A 5 to 10 second total light-up period is satisfactory. If ignition takes longer, consult your local authorized dealer / distributor.
7. Check that the gasketing on the sides, top and bottom of the door is not broken or missing. Replace if necessary.
8. If for any reason the vent air intake system is disassembled, re-install and re-seal per the instructions provided for the initial installation.

9.0 REPLACEMENTS

Contact your dealer or the factory for questions concerning prices and policies on replacement parts. Normally all parts can be ordered through your Authorized dealer / distributor.

FOR WARRANTY REPLACEMENT PARTS, A PHOTOCOPY OF THE ORIGINAL INVOICE WILL BE REQUIRED TO HONOUR THE CLAIM.

When ordering replacement parts always give the following information:

- Model & Serial Number of appliance
- Installation date of appliance
- Part number
- Description of part
- Finish

WARNING

Failure to position the parts in accordance with this manual or failure to use only parts specifically approved with this appliance may result in property damage or personal injury.

* IDENTIFIES ITEMS WHICH ARE NOT ILLUSTRATED. FOR FURTHER INFORMATION, CONTACT YOUR AUTHORIZED DEALER.

41.1

COMPONENTS		
REF NO.	PART NO.	DESCRIPTION
1	W225-0216	DOOR FRAME
2*	W562-0008	DOOR GASKET
3*	W010-1736	DOOR LATCH ASSEMBLY
4	W010-1743	GLASS C/W GASKET
5*	W300-0088	GLASS
6	W100-0104	BURNER
7	W357-0006	IGNITOR
8	W190-0026	CONTROL, MODULE
9*	W750-0183	WIRE HARNESS
10*	W750-0184	IGNITION CABLE
11	W200-0234	IGNITOR COVER
12	W200-0233	BURNER COVER
13	W725-0052	NATURAL GAS VALVE - 3.5" W.C.
13	W725-0053	PROPANE GAS VALVE - 10.0" W.C.
14*	W455-0085	NATURAL GAS ORIFICE
14*	W455-0086	PROPANE GAS ORIFICE
15	W010-1961	FIRESTOP ASSEMBLY
16	W475-0522	BACK PANEL
17*	W300-0108	ACCENT GLASS (BLACK)
18*	W385-0334	NAPOLEON® LOGO
19	W290-0123	EXHAUST GASKET
20	W290-0125	BURNER GASKET
21*	W562-0046	ROPE GASKET, BACK PANEL
22	TFK	TORCH® FRAME - PAINTED METALLIC BLACK FINISH
22	TFR	TORCH® FRAME - RED FINISH
22	TFP	TORCH® FRAME - PEWTER FINISH
22	TFW	TORCH® FRAME - WHITE FINISH
22	TFB	TORCH® FRAME - STEEL BLUE FINISH
FLEXIBLE VENT KITS		
REF NO.	PART NO.	DESCRIPTION
GDT5 (5 FT)		
23*	W730-0031	3" FLEXIBLE VENT PIPE - (5 FT)
24*	W730-0032	5" FLEXIBLE VENT PIPE - (5 FT)
25*	W615-0080	SPACERS (3 INCLUDED)
GDT10 (10 FT)		
26*	W730-0033	3" FLEXIBLE VENT PIPE - (10 FT)
27*	W730-0034	5" FLEXIBLE VENT PIPE - (10 FT)
25*	W615-0080	SPACERS (3 INCLUDED)

TERMINAL KITS

REF NO.	PART NO.	DESCRIPTION
GD178 (WALL TERMINAL KIT)		
28*	W010-1744	12" FLEXIBLE VENT ASSEMBLY
29	W670-0013	3"/5" HORIZONTAL TERMINAL
GD179 (TERMINAL ONLY)		
29	W670-0013	3"/5" HORIZONTAL TERMINAL

ROOF TERMINAL KITS

REF NO.	PART NO.	DESCRIPTION
GDT113		
30*	W670-0013	AIR TERMINAL
31*	W490-0076	3/5 INNER/OUTER SLEEVE
GDT110 (1/12 - 7/12 PITCH)		
30*	W670-0013	AIR TERMINAL
31*	W490-0076	3/5 INNER/OUTER SLEEVE
32*	W010-1844	ROOF SUPPORT
33*	W263-0099	ROOF FLASHING
34*	W170-0134	STORM COLLAR
GDT111 (8/12 - 12/12 PITCH)		
30*	W670-0013	AIR TERMINAL
31*	W490-0076	3/5 INNER/OUTER SLEEVE
32*	W010-1844	ROOF SUPPORT
33*	W263-0100	ROOF FLASHING
34*	W170-0134	STORM COLLAR
GDT112 (FLAT ROOF)		
30*	W670-0013	AIR TERMINAL
31*	W490-0076	3/5 INNER/OUTER SLEEVE
32*	W010-1844	ROOF SUPPORT
33*	W263-0101	ROOF FLASHING
34*	W170-0134	STORM COLLAR

ACCESSORIES

REF NO.	PART NO.	DESCRIPTION
35*	W573-0002	HIGH TEMPERATURE SEALANT
35*	W573-0007	HIGH TEMPERATURE SEALANT
36*	W175-0204	3" COUPLER
37*	W175-0166	5" COUPLER
38*	W175-0270	CONVERSION KIT - NG TO LP
39*	W175-0274	CONVERSION KIT - LP TO NG
40*	W175-0271	COUPLER KIT
41*	LK8	LIGHT KIT
42*	AVS35KT	VENT SLEEVE ASSEMBLY

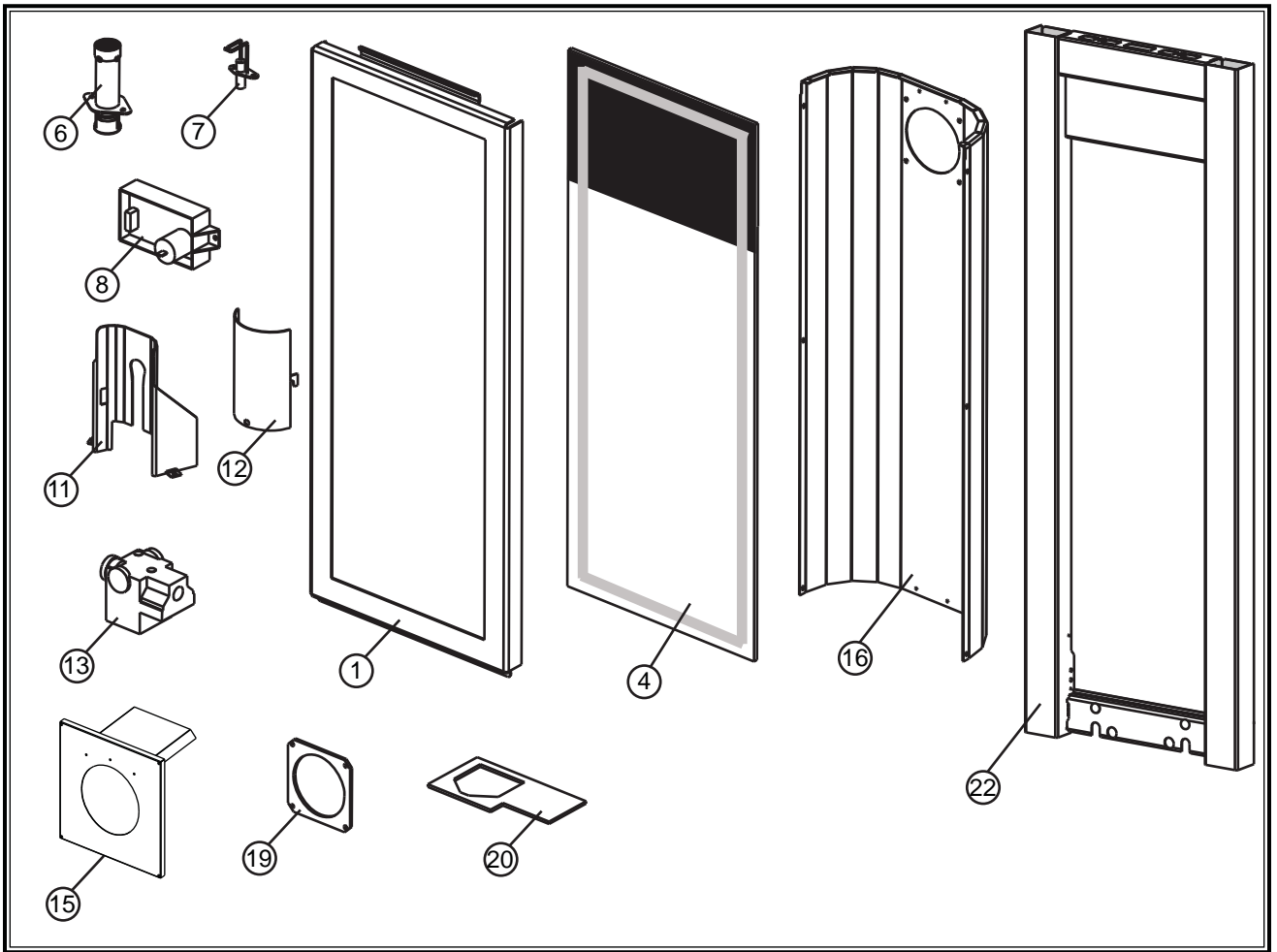

! WARNING

ALWAYS LIGHT THE PILOT WHETHER FOR THE FIRST TIME OR IF THE GAS SUPPLY HAS RAN OUT, WITH THE GLASS DOOR OPEN OR REMOVED.

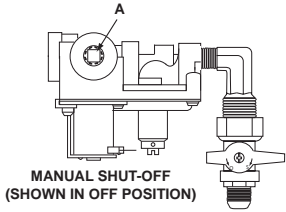
SYMPTOM	PROBLEM	TEST SOLUTION
Electrode sparks, burner ignites, electrode continues to spark for complete 7 seconds, burner shuts down.	Hot and neutral wires are reversed at control module.	- Connect the hot wire to the black wire. Connect the neutral wire to the white wire.
	Sensor / flame not connecting	- Raise electrode / sensor up into flame.
Main burner flame is a blue, lazy, transparent flame.	Blockage in vent.	- Remove blockage. In extremely cold conditions, ice buildup may occur on the terminal and should be removed as required.
Flame length consistently too large or too small. Carboning occurs.	Unit is over-fired or under-fired.  <small>MANUAL SHUT-OFF (SHOWN IN OFF POSITION)</small>	- Check pressure readings
		- Outlet pressure can be checked by removing cap (A) and replacing it with a 1/8" NPT barb fitting. Next, place pressure gauge tubing over the fitting. Gauge should read 3.5" W.C. for natural gas or 10.0" W.C. for propane. AFTER TAKING PRESSURE READINGS, BE SURE TO REPLACE CAP TO RESEAL. DO NOT OVER-TORQUE.
Carbon is being deposited on glass, logs or combustion chamber surfaces.	Air shutter has become blocked.	- Ensure air shutter opening is free of lint or other obstructions.
	Flame is impinging on the combustion chamber.	- Open air shutter to increase the primary air. - Check the input rate: check the manifold pressure and orifice size as specified by the rating plate values. - Check that the door gasketing is not broken or missing and that the seal is tight. - Check that both 3" and 5" vent liners are free of holes and well sealed at all joints. - Check that the minimum rise per foot has been adhered to for any horizontal venting.
White / grey film forms.	Sulphur from fuel is being deposited on glass, logs or combustion chamber surfaces.	- Clean the glass with a gas fireplace glass cleaner. DO NOT CLEAN GLASS WHEN HOT. If deposits are not cleaned off regularly, the glass may become permanently marked.
Exhaust fumes smelled in room, headaches.	Fireplace is spilling.	- Check door seal.
		- Check pressure relief device.
		- Check for chimney blockage.
		- Ensure that the paint curing process is complete.
No gas to the main burner; switch is on.	Switch is defective.	- Connect a jumper wire across the wall switch terminals; if main burner lights, replace switch / thermostat.
	Burner orifice is blocked.	- Remove stoppage in orifice.
	Control valve faulty.	- Replace.
	Faulty valve.	- Replace.
Burner will not light, ignitor sparks.	No gas at the burner.	- Check that the manual valve is turned on. - Replace the valve.
	Out of propane gas.	- Fill the tank.

